

Liquid - Vapor

Contacting columns

Distillation Column Design

The design of a distillation column can be divided into the following steps:

1. Specify the degree of separation required: set product specifications.

2. Select the operating conditions: batch or continuous; operating pressure.

3. Select the type of contacting device: plates or packing.

4. Determine the stage and reflux requirements: the number of equilibrium stages.

5. Size the column: diameter, number of real stages.

6. Design the column internals: plates, distributors, packing supports.

7. Mechanical design: vessel and internal fittings.

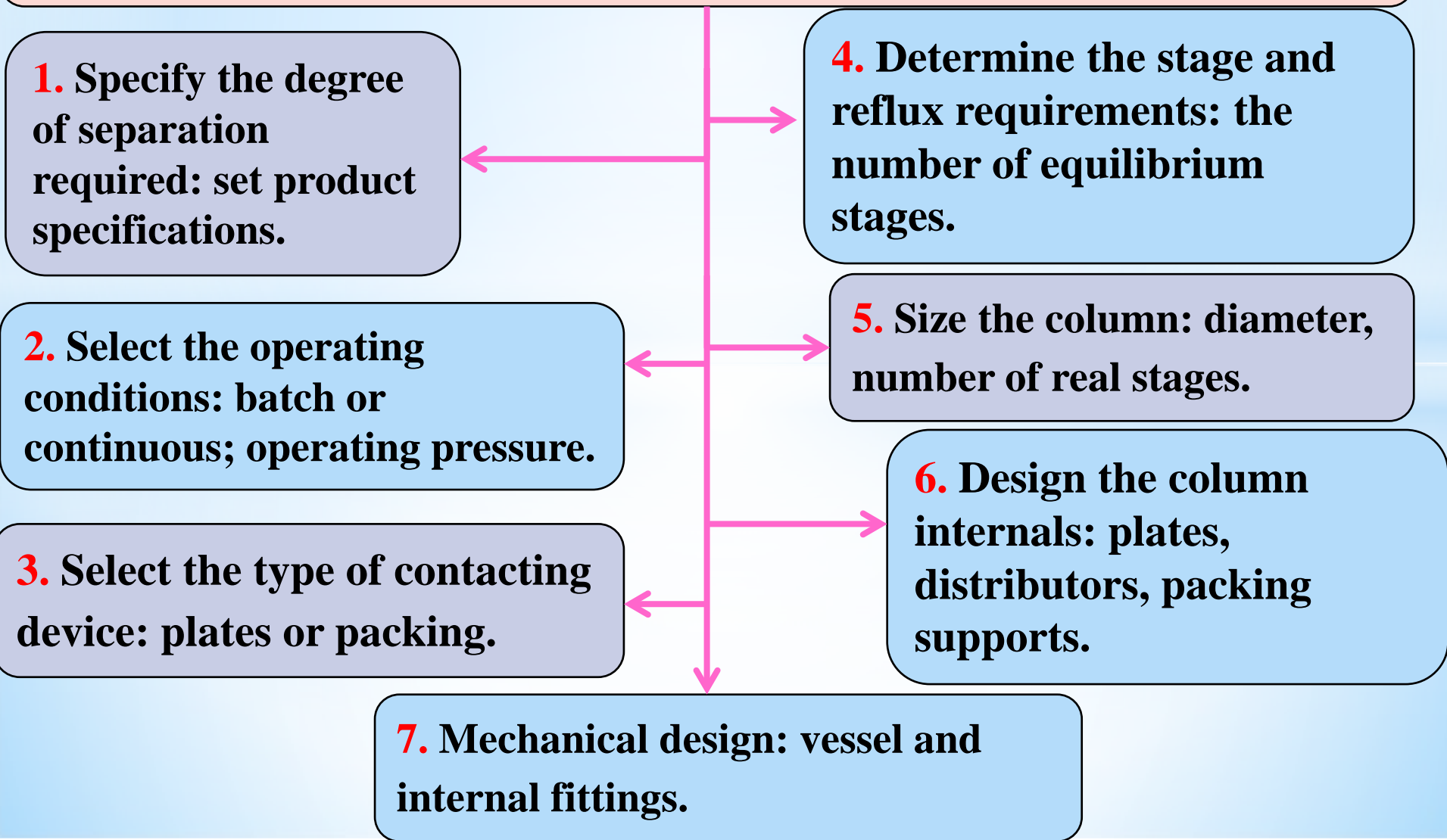

CONTINUOUS DISTILLATION: PROCESS DESCRIPTION

- The separation of liquid mixtures by distillation depends on differences in volatility between the components.
- The greater the relative volatilities, the easier is the separation.
- Vapor flows up the column, and liquid counter-currently flows down the column.
- The vapor and liquid are brought into contact on *plates or packing*.

CONTINUOUS DISTILLATION: PROCESS DESCRIPTION

The basic equipment required for continuous distillation is shown in Figure :-

- Figure (1a) : shows a column producing two product streams, referred to as **tops or overheads** and **bottoms**, from a single feed.
- Columns are occasionally used with **more than one feed**, and with side streams withdrawn at points up the column, as in Figure (1b).

This does not alter the basic operation but complicates the analysis of the process to some extent.

CONTINUOUS DISTILLATION: PROCESS DESCRIPTION

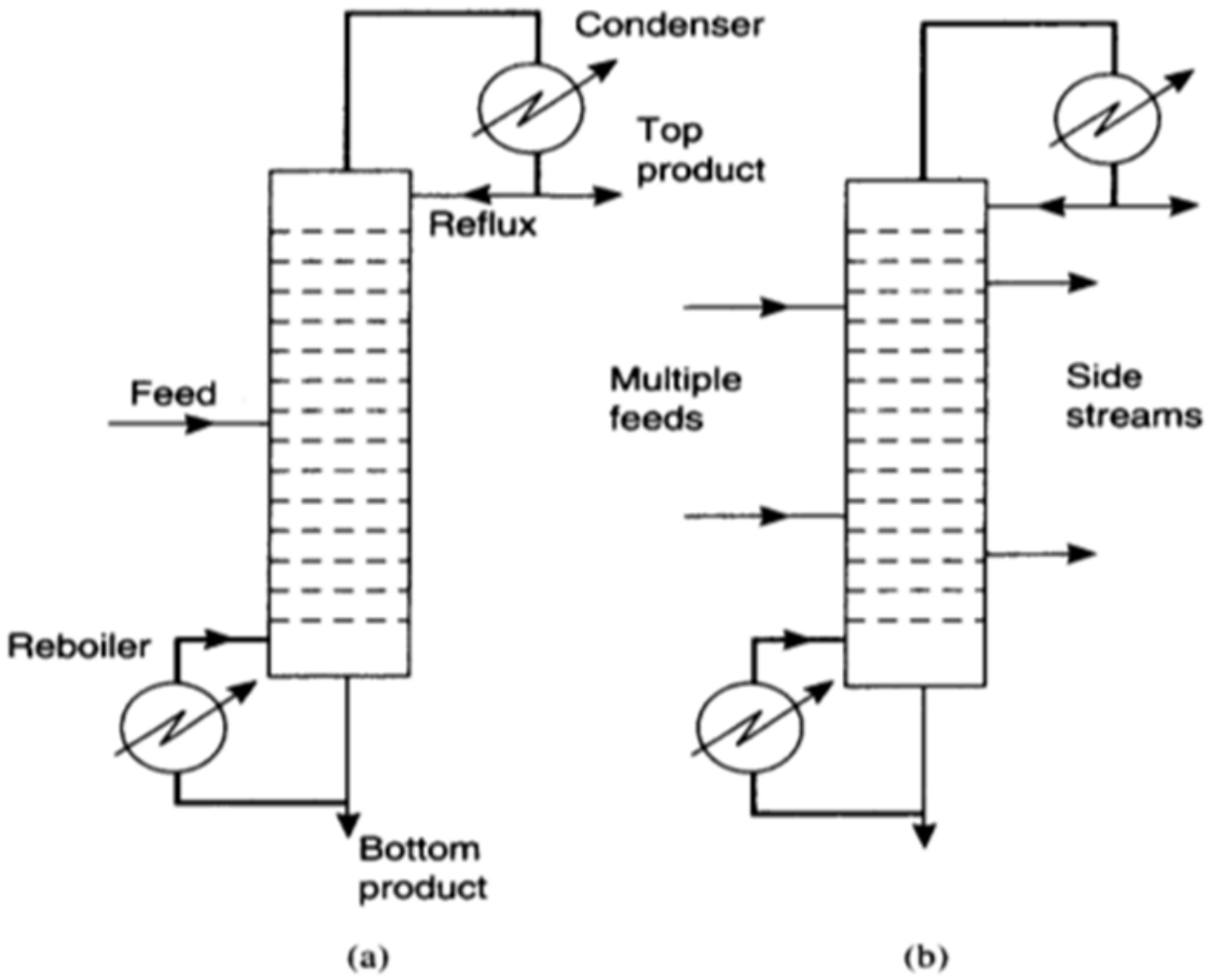

Figure 11.1. Distillation column (a) Basic column (b) Multiple feeds and side streams

CONTINUOUS DISTILLATION: PROCESS DESCRIPTION

- **Part of the condensate**

- From the condenser is returned to the top of the column to provide liquid flow above the feed point (**Reflux**).
- Part of the liquid from the base of the column is vaporized in the reboiler and returned to provide the vapor flow.
- In the section below the feed, the more volatile components are stripped from the liquid; this is known as the **stripping section**.
- Above the feed, the concentration of the more volatile components is increased; this is called the **enrichment**, or more commonly the **rectifying section**.

Reflux Considerations

❖ **The reflux ratio (R):** is normally defined as

$$R = \frac{\text{flow returned as reflux}}{\text{flow of top product taken off}}$$

The number of stages required for a given separation will be dependent on the reflux ratio used.

❖ **Total Reflux:** is the condition when all the condensate is returned to the column as reflux: no product is taken off and there is no feed.

- At total reflux the number of stages required for a given separation **is the minimum** at which it is theoretically possible to achieve the separation.

CONTINUOUS DISTILLATION

❖ **Minimum Reflux:** As the reflux ratio is reduced, a pinch point will occur at which the separation can be achieved only with an infinite number of stages.

This sets the minimum possible reflux ratio for the specified separation.

❖ **Optimum Reflux Ratio:** Practical reflux ratios will lie somewhere between the minimum for the specified separation and total reflux.

➤ **For many systems the optimum will lie between 1.2 and 1.5 times the minimum reflux ratio.**

CONTINUOUS DISTILLATION

➤ Plate Design Parameters:

The significance of the **weir height** in the **AIChE** equations should be noted, the weir height was the plate parameter found to have the most significant effect on plate efficiency.

- Increasing weir height will increase the plate efficiency, but at the expense of an increase in pressure drop and entrainment.
- Weir heights will normally be in the range **40 to 100mm** for columns operating at and above atmospheric pressure, but will be as low as **6mm** for vacuum columns.

CONTINUOUS DISTILLATION

➤ APPROXIMATE COLUMN SIZING

- An approximate estimate of the overall column size can be made once **the number of real stages** required for the separation is known.

This is often needed to make a rough estimate of the capital cost for project evaluation.

➤ Plate Spacing

- The overall height of the column will **depend on the plate spacing**. Plate spacings from ***0.15m (6 in.) to 1m (36 in.)*** are normally used.
- The spacing chosen will depend on the **column diameter and operating conditions**.
- For columns above ***(1m)diameter***, plate spacing's of ***(0.3 to 0.6m)***.

CONTINUOUS DISTILLATION

Column Diameter: The principal factor that determines the column diameter is the vapor flow rate.

PLATE CONTACTORS

- **Cross-flow plates** are the most common type of plate contactor used in distillation and absorption columns.
- In a cross-flow plate, the liquid flows across the plate and the vapor up through the plate.
- A typical layout is shown in Figure. The flowing liquid is transferred from plate to plate through vertical channels called **downcomers**.
- A pool of liquid is retained on the plate by an outlet **weir**.

CONTINUOUS DISTILLATION

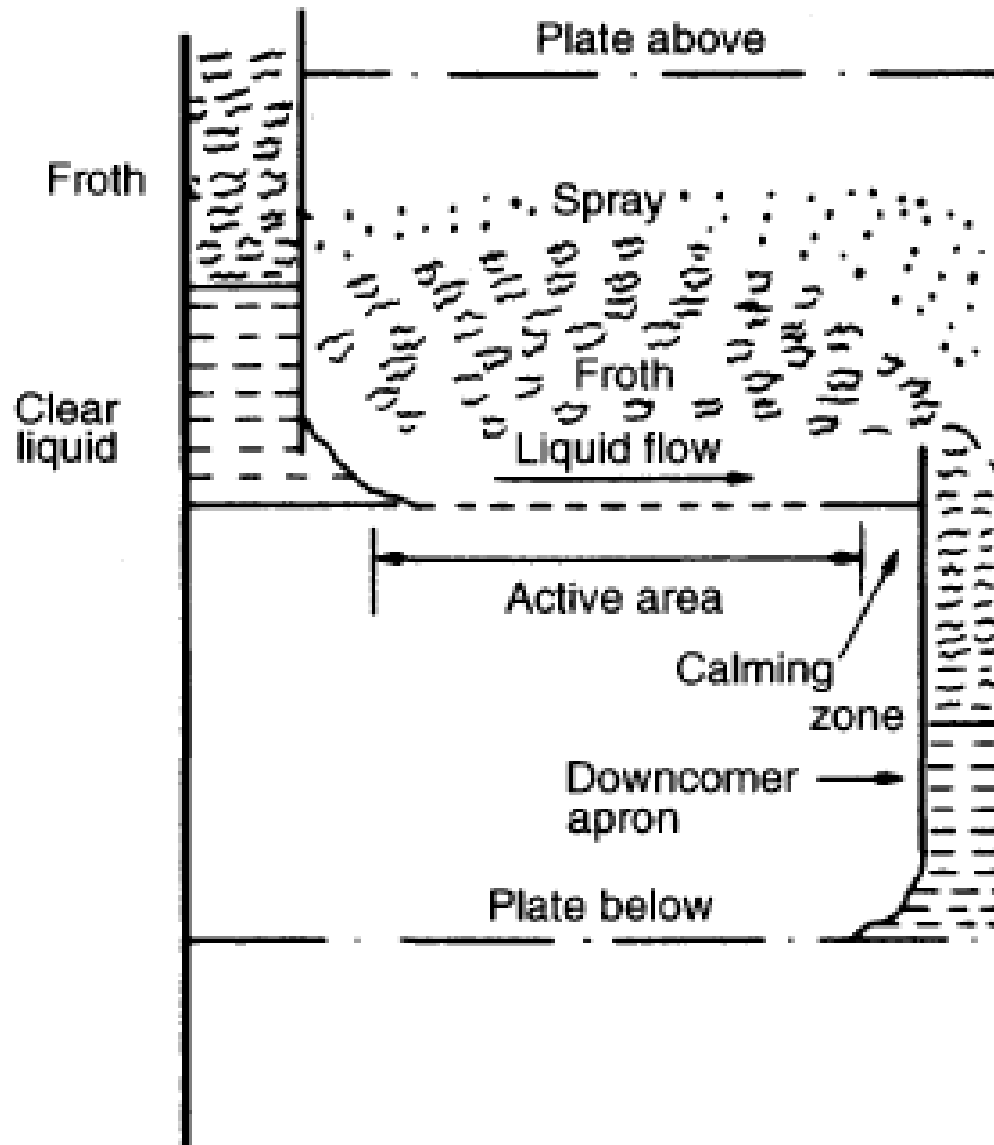

Typical cross-flow plate (sieve)

CONTINUOUS DISTILLATION

Three principal types of cross-flow tray are used, classified according to **the method used to contact the vapour and liquid.**

1. Sieve Plate (Perforated Plate)

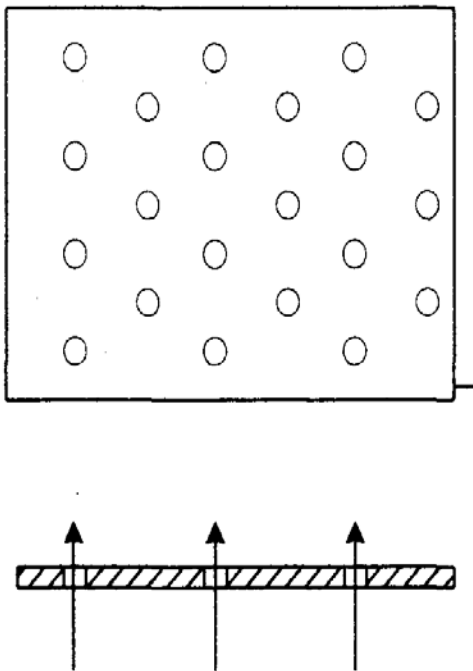

2. Bubble-Cap Plates

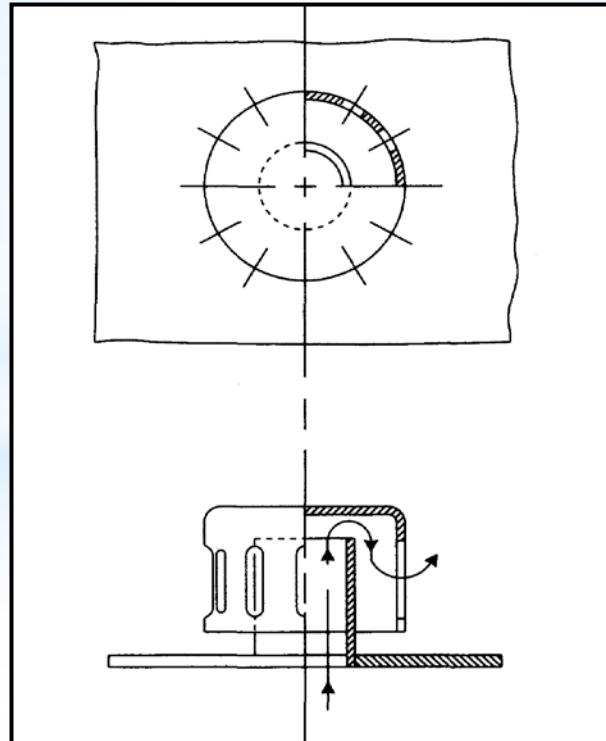

3. Valve Plates (Floating Cap Plates)

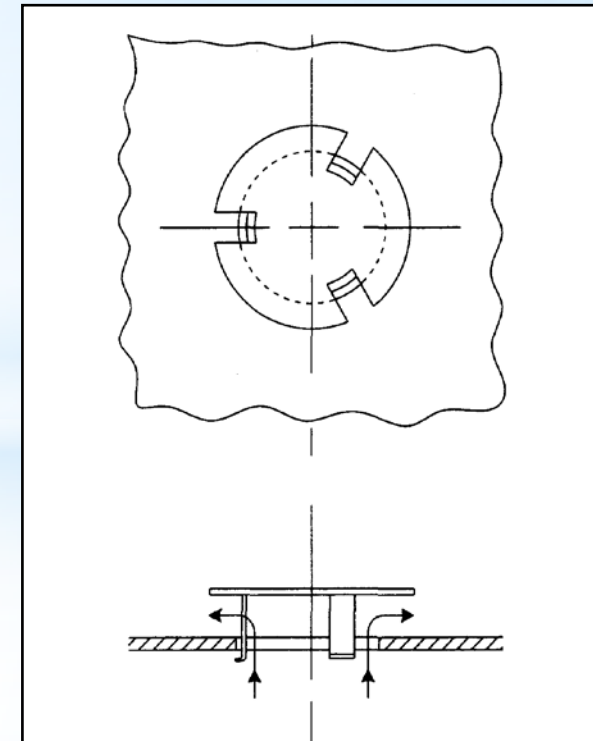

1. Sieve Plate (Perforated Plate)

- The sieve plate is the **simplest** type of cross-flow plate (see Figure).
- The vapor passes up through perforations in the plate, and the liquid is retained on the plate by the vapor flow.
- There is no positive vapor-liquid seal, and at low flow rates liquid will “weep” through the holes, **reducing the plate efficiency.**
- The perforations are usually small holes, but larger holes and slots are used.

2. Bubble-Cap Plates

- ❖ In bubble-cap plates, the vapor passes up through short pipes, called **risers (ensures that a level of liquid is maintained on the tray at all vapour flow-rates)**, covered by a cap with a serrated edge, or slots (see Figure).
- ❖ The bubble-cap plate is the traditional, oldest type of cross-flow plate,

3. Valve Plates (Floating Cap Plates)

- Valve plates are proprietary designs (see Figure).
- They are essentially sieve plates with large-diameter holes covered by movable flaps, which lift as the vapor flow increases.
- As the area for vapour flow varies with the flow-rate, valve plates can operate **efficiently** at lower flow-rates than sieve plates: the valves closing at low vapour rates.

Liquid Flow Pattern

- Cross-flow trays are also classified according to the **number of liquid passes** on the plate.
- **Single-pass plate**, shown in Figure (a).
- For low liquid flow rates **reverse flow plates** are used; Figure(b). In this type the plate is divided by a low central partition, and inlet and outlet downcomers are on the same side of the plate.
- **Multiple or double pass plates**; Figure(c), in which the liquid stream is sub divided by using several downcomers, are used for high liquid flow-rates and large diameter columns..

CONTINUOUS DISTILLATION

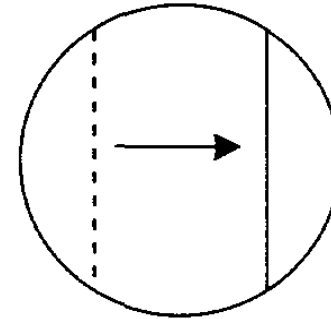
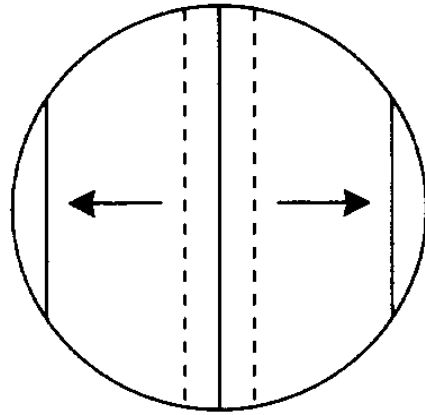

(a)

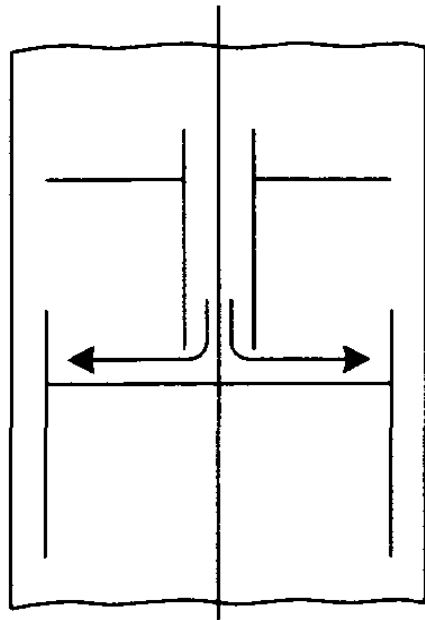

(c)

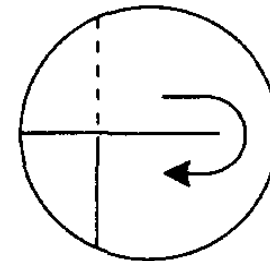

(b)

Selection of Plate Type

The principal factors to consider when comparing the performance of bubble-cap, sieve, and valve plates are:

Cost

capacity

operating range

efficiency

Pressure drop

a- Cost

Bubble-cap plates are appreciably more expensive than sieve or valve plates. The relative cost will depend on the material of construction used.

b- Capacity

The ranking is sieve, valve, bubble-cap tray, (the diameter of the column required for a given flow-rate).

c- Operating range

- The ratio of the highest to the lowest flow rates is **Bubble-cap plates have a positive liquid seal** and can therefore operate efficiently at **very low vapor rates**.
- **With good design, sieve plates** can be designed to give a satisfactory operating range, typically, from **50 to 120%** of design capacity.
- **Valve plates** are intended to give greater flexibility than **sieve plates** at a lower cost than **bubble caps**.
- Efficiency Pressure drop: in general, **sieve plates** give the lowest pressure drop, followed by **valves**, with **bubble caps** giving the highest.

Plate Construction

Downcomers

The segmental, or chord downcomer, shown in Figure (a) is the simplest and cheapest form of construction and is satisfactory for most purposes.

The downcomer channel is formed by a flat plate, called an **apron**, which extends down from the outlet weir. The apron is usually vertical but may be sloped, to increase the plate area available for perforation. See Figure (b)

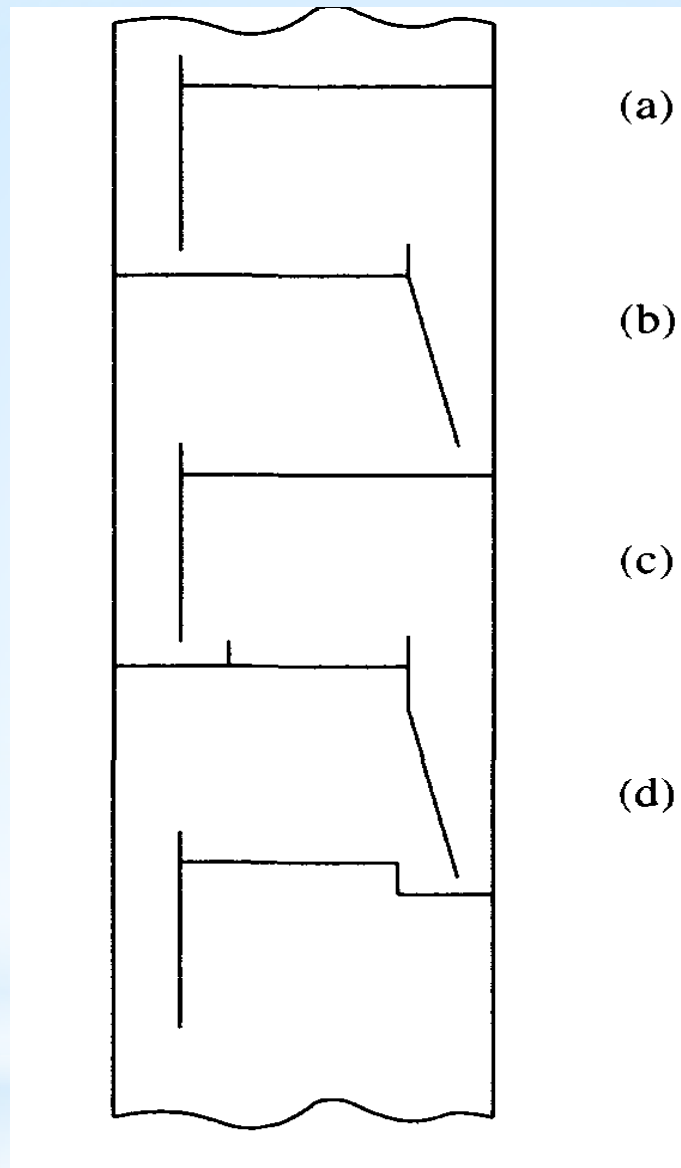

Segment (chord) downcomer designs. (a) Vertical apron. (b) Inclined apron. (c) Inlet weir. (d) Recessed well.

CONTINUOUS DISTILLATION

Side Stream and Feed Points

- ❖ Where a side-stream is withdrawn from the column the plate design must be modified to provide a liquid seal at the take-off pipe. A typical design is shown in Figure (a).
- ❖ When the feed stream is liquid it will be normally introduced into the downcomer leading to the feed plate, and the plate spacing **increased** at this point; Figure (b).

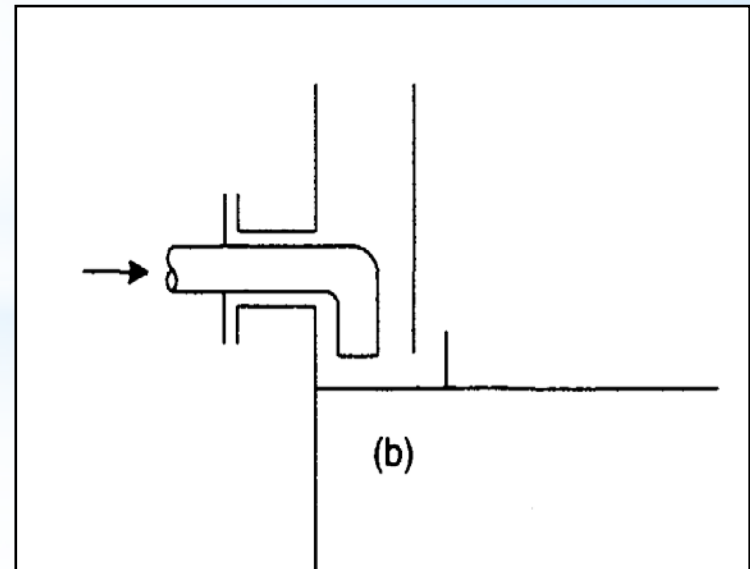
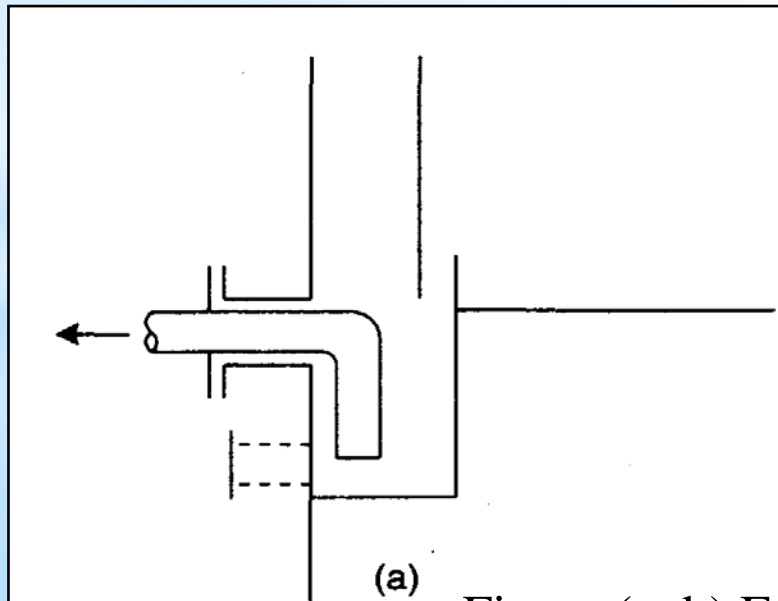

Figure (a, b) Feed and takeoff nozzles.

PLATE HYDRAULIC DESIGN

The basic requirements of a plate contacting stage are that it should:

1- Provide good vapour-liquid contact.

2- provide sufficient liquid holdup for good mass transfer (high efficiency).

3- Have sufficient area and spacing to keep the entrainment and pressure drop within acceptable limits.

4- Have sufficient downcomer area for the liquid to flow freely from plate to plate

Operating Range

Satisfactory operation will only be achieved over a limited range of vapour and liquid flow rates.

A typical performance diagram for a sieve plate is shown in Figure.

- **At flooding**, there is a sharp drop in plate efficiency and increase in pressure drop. Flooding is caused by either the excessive carry over of liquid to the next plate by entrainment, or by liquid backing-up in the downcomers.
- The lower limit of the vapor flow is set by the condition of weeping. Weeping occurs when the vapor flow is insufficient to maintain a level of liquid on the plate.
- **Coning** occurs at low liquid rates and is the term given to the condition where the vapour pushes the liquid back from the holes and jets upward, with poor liquid contact.

CONTINUOUS DISTILLATION

Sieve plate performance diagram.

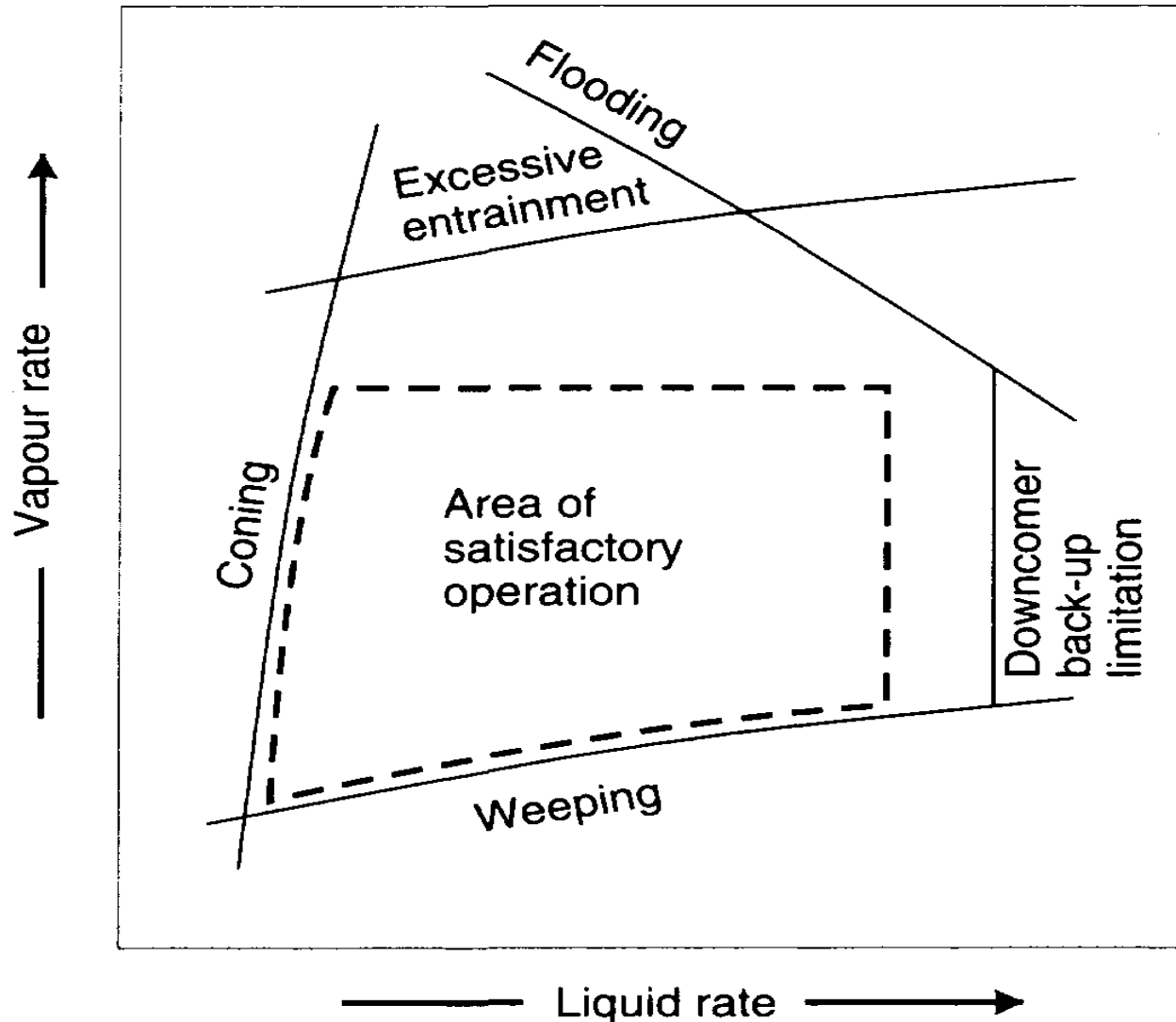

Plate-Design Procedure

A trial-and-error approach is necessary in plate design: starting with a rough plate layout, checking key performance factors, and revising the design, as necessary, until a satisfactory design is achieved.

Procedure:

1. Calculate the maximum and minimum vapor and liquid flow rates, for the turndown ratio required.
2. Collect or estimate the system physical properties.
3. Select a trial plate spacing.
4. Estimate the column diameter, based on flooding considerations.
5. Decide the liquid flow arrangement.

CONTINUOUS DISTILLATION

6. Make a trial plate layout: downcomer area, active area, hole area, hole size, weir height.
7. Check the weeping rate ; if unsatisfactory, return to step 6.
8. Check the plate pressure drop; if too high, return to step 6.
9. Check downcomer backup; if too high, return to step 6 or 3.
10. Decide plate layout details: calming zones, un perforated areas.
Check hole pitch; if unsatisfactory, return to step 6.
11. Recalculate the percentage flooding based on chosen column diameter.
12. Check entrainment; if too high, return to step 4.

CONTINUOUS DISTILLATION

13. Optimize design: repeat steps 3 to 12 to find smallest diameter and plate spacing acceptable (lowest cost).
14. Finalize design: draw up the plate specification and sketch the layout.

Plate Areas

The following area terms are used in the plate design procedure:

A_c = total column cross-sectional area;

A_d = cross-sectional area of downcomer;

A_n = net area available for vapor-liquid disengagement, normally equal to $A_c - A_d$, for a single pass plate;

A_a = active, or bubbling, area, equal to $A_c - 2A_d$ for single-pass plates;

A_h = hole area, the total area of all the active holes;

A_p = perforated area (including blanked areas);

A_{ap} = the clearance area under the downcomer apron.

Diameter

- The flooding condition fixes the upper limit of vapor velocity.
- A high vapor velocity is needed for high plate efficiencies, and the velocity will normally be between **70 and 90%** of that which would cause flooding.
- **For design, a value of 80 to 85% of the flooding velocity should be used.**
- The flooding velocity can be estimated from the correlation given by Fair (1961):

$$u_f = K_1 \sqrt{\frac{\rho_L - \rho_v}{\rho_v}}$$

CONTINUOUS DISTILLATION

$$u_f = K_1 \sqrt{\frac{\rho_L - \rho_v}{\rho_v}}$$

Where:

u_f = flooding vapor velocity, m/s, based on the net column cross-sectional area **An**

K_1 = a constant obtained from Figure.

The liquid-vapor flow factor FLV in Figure is given by

$$F_{LV} = \frac{L_w}{V_w} \sqrt{\frac{\rho_v}{\rho_L}}$$

Where :

L_w = liquid mass flow rate, kg/s.

V_w = vapor mass flow rate, kg/s.

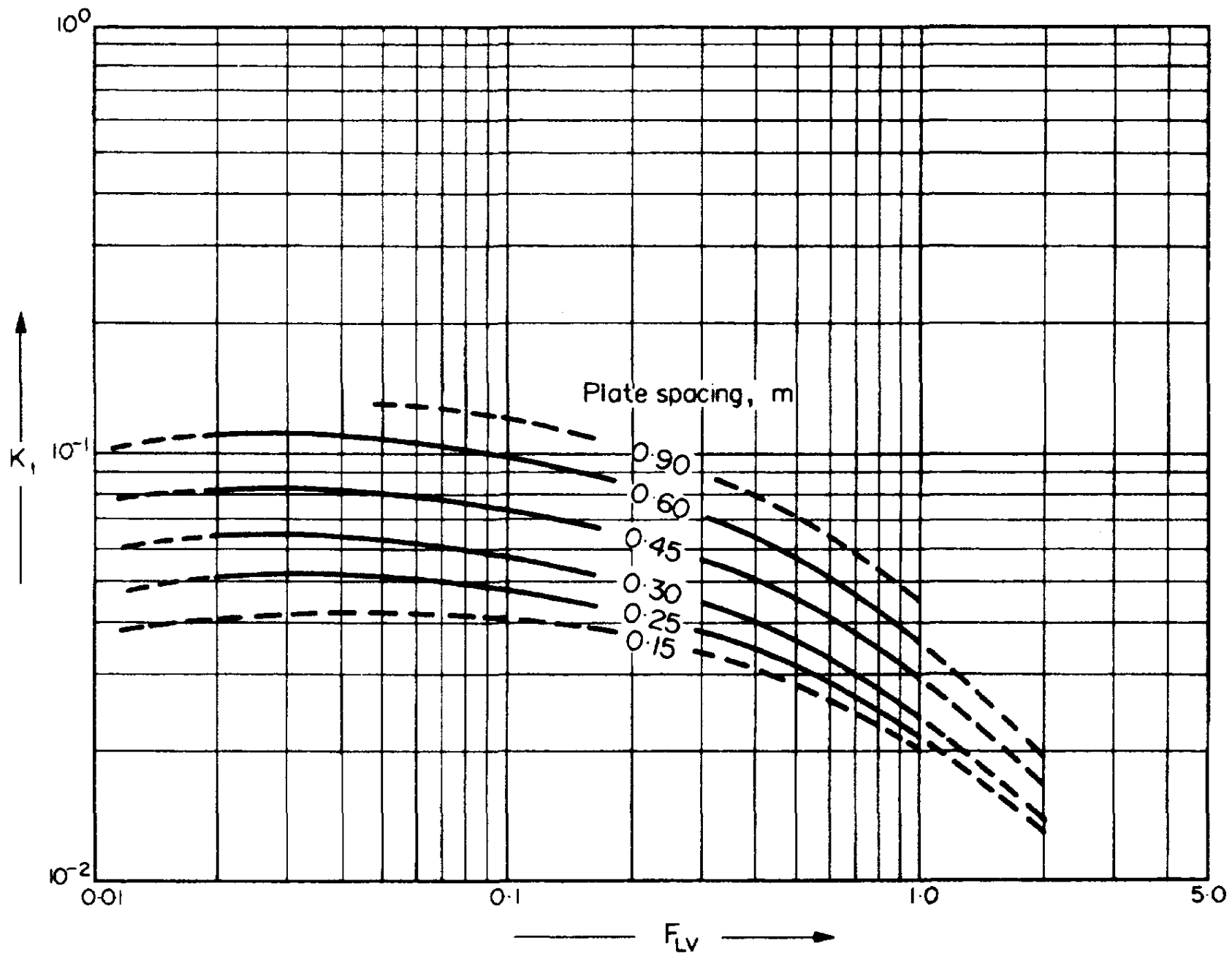

Figure*: Flooding velocity, sieve plate

CONTINUOUS DISTILLATION

The following restrictions apply to the use of Figure*:

1. Hole size less than 6.5 mm. Entrainment may be greater with larger hole sizes.
 2. Weir height less than 15% of the plate spacing.
 3. Non foaming systems.
 4. Hole: active area ratio greater than 0.10;
- **for other ratios apply the following corrections:**

hole: active area	multiply K1 by
0.10	1.0
0.08	0.9
0.06	0.8

CONTINUOUS DISTILLATION

5. Liquid surface tension 0.02 N/m; for other surface tensions σ , multiply the value of K_1 by $[\sigma / 0.02]^{0.2}$.

To calculate the column diameter, an estimate of the net area (**An**) is required.

As a first trial, take the downcomer area as **12%** of the total and assume that the hole – active area is **10%**.

For distillation, it will usually be sufficient to design for the conditions above and below the feed points.

Liquid-Flow Arrangement

The choice of plate type (reverse, single-pass, or multiple-pass) will depend on the liquid flow rate and column diameter.

An initial selection can be made using the following Figure

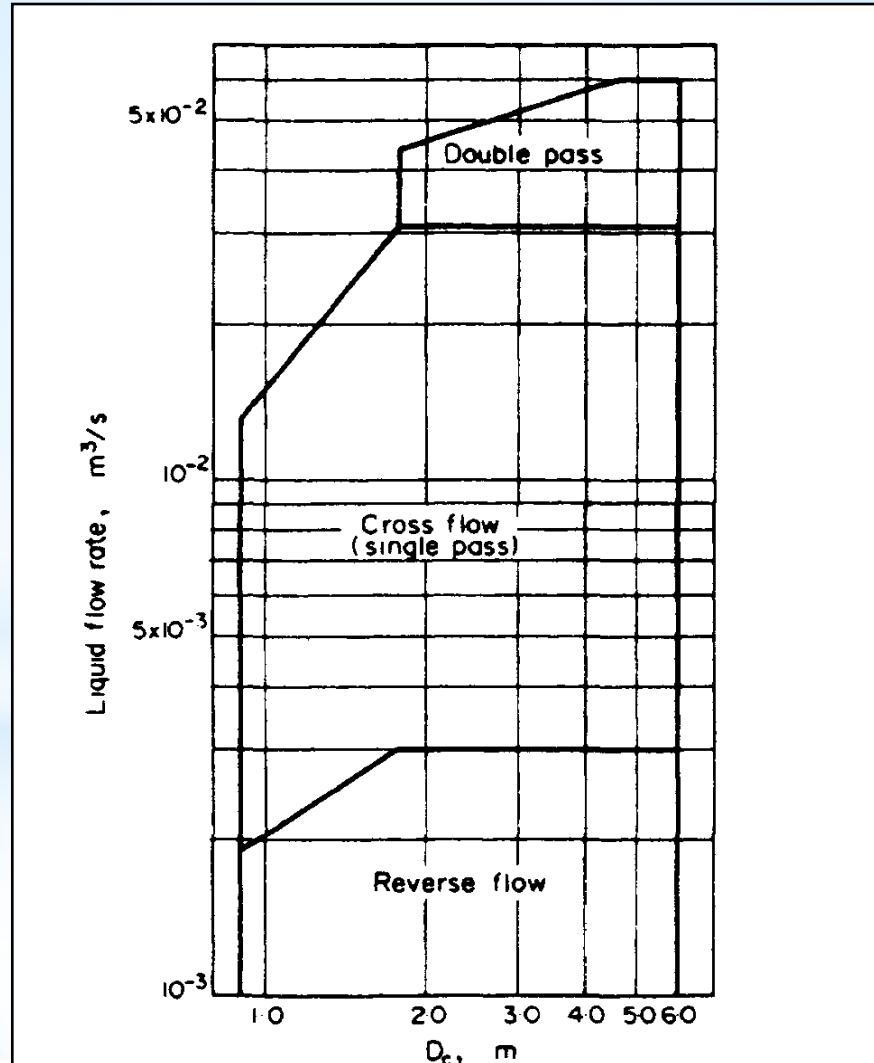

Figure. Selection of liquid-flow arrangement.

Entrainment

Entrainment can be estimated from the correlation given by Fair (1961) Figure#, which gives the fractional entrainment

ψ (kg/kg gross liquid flow) as a function of the liquid-vapour factor F_{LV} with the percentage approach to flooding as a parameter.

The percentage flooding is given by:

$$\text{percentage flooding} = \frac{u_n \text{ actual velocity (based on net area)}}{u_f \text{ (from equation 11.81)}}$$

$$u_f = K_1 \sqrt{\frac{\rho_L - \rho_v}{\rho_v}} \quad (11.81)$$

As a rough guide, the **upper limit of c can be taken as 0.1;**

Figure (#): Entrainment correlation for sieve plates (Fair, 1961)

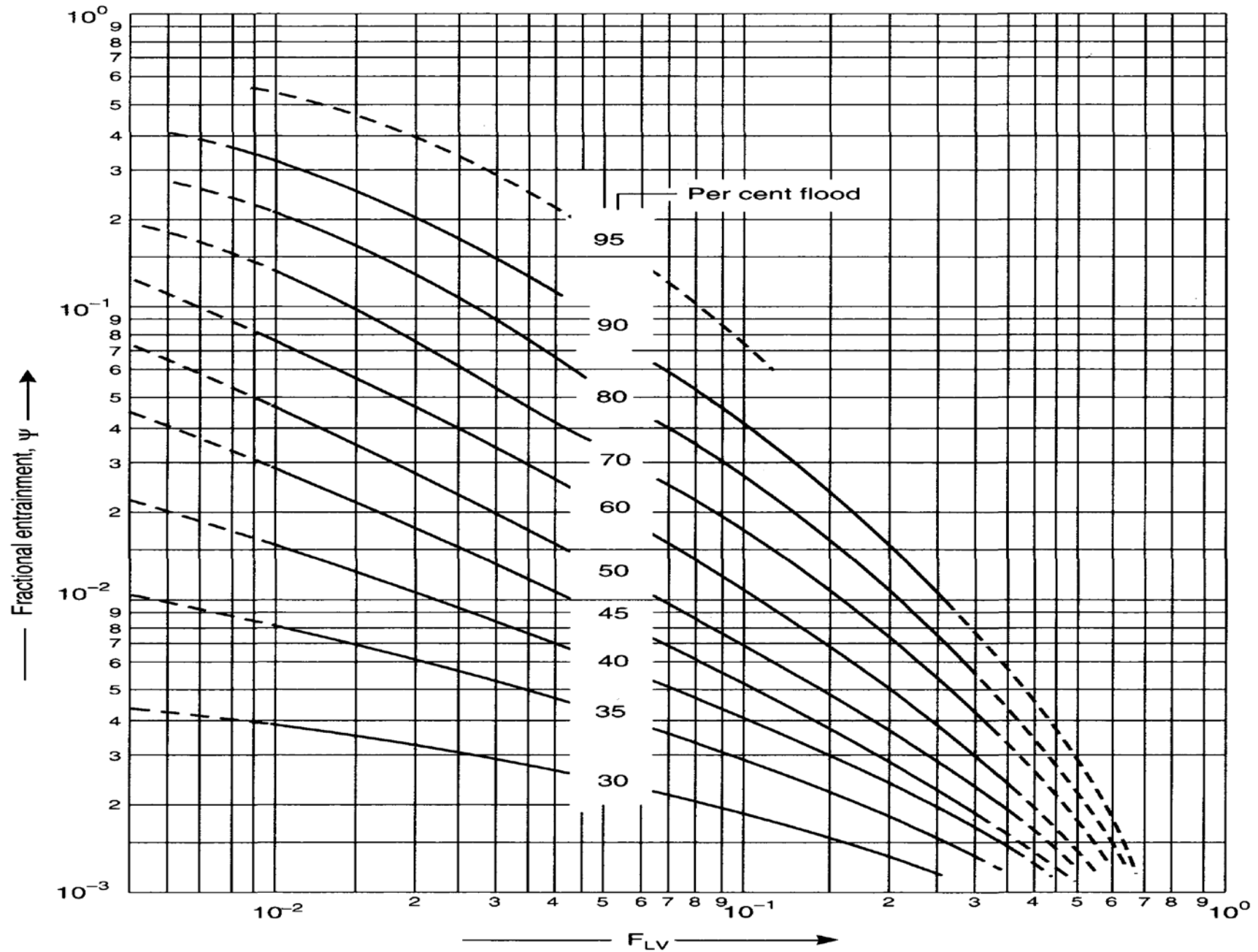

Weep Point

- ❑ Is the lower limit of the operating range occurs when liquid leakage through the plate holes becomes excessive.
- ❑ The vapour velocity at the weep point is the minimum value for stable operation.
- ❑ The hole area must be chosen so that at the lowest operating rate the vapour flow velocity is still well above the weep point.

The minimum design vapour velocity is given by:

$$\check{u}_h = \frac{[K_2 - 0.90(25.4 - d_h)]}{(\rho_v)^{1/2}}$$

Where:

\hat{u}_h = minimum vapour velocity through the holes (based on the hole area), m/s.

d_h = hole diameter, mm.

K_2 = a constant, dependent on the depth of clear liquid on the plate, obtained from the following Figure.

The clear liquid depth is equal to the height of the weir h_w plus the depth of the crest of liquid over the weir h_{ow} , this is discussed in the next section.

Weep-point correlation
(Eduljee, 1959).

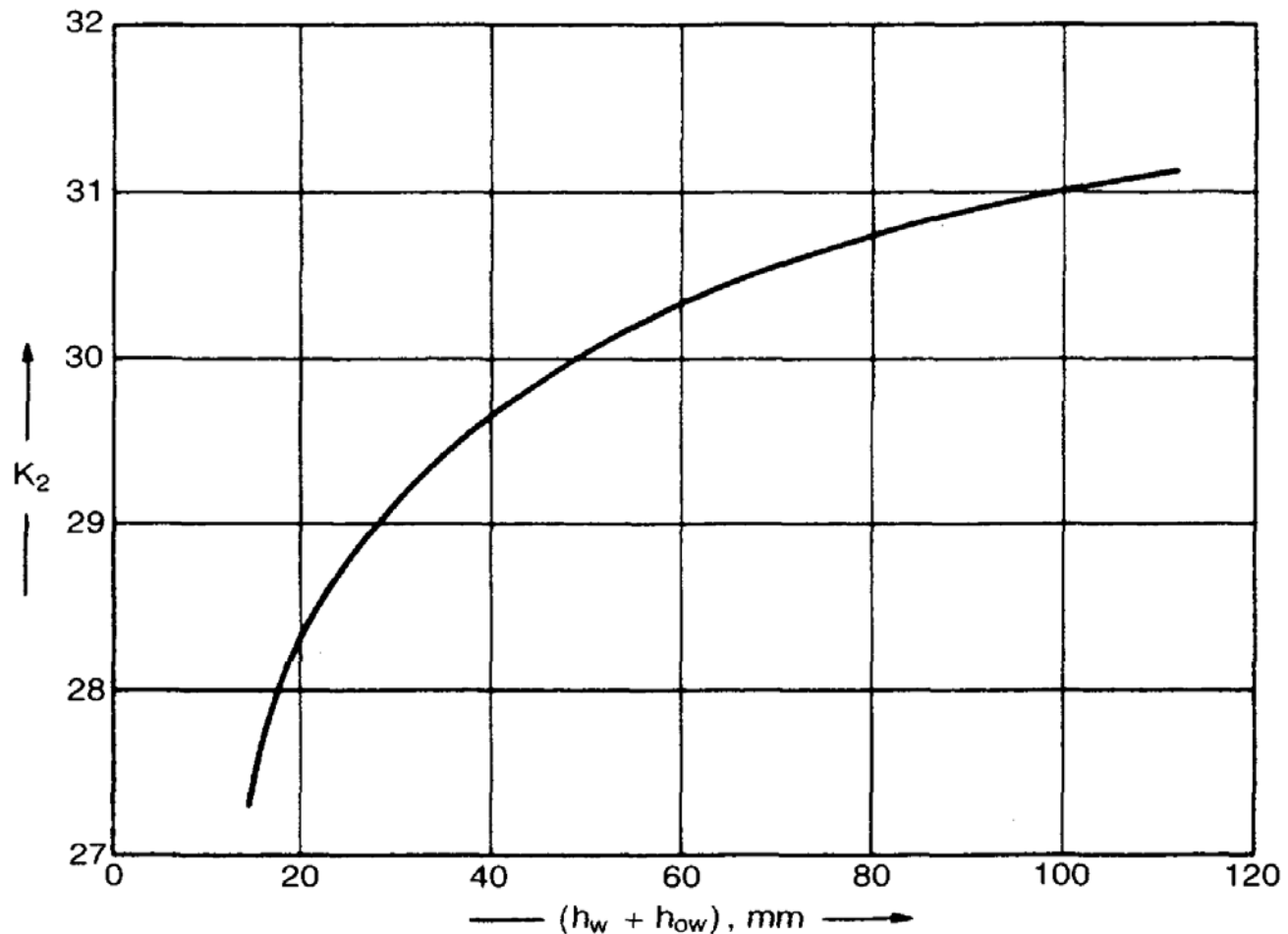

Weir Liquid Crest

- The height of the liquid crest over the weir can be estimated using the Francis weir formula.

For a segmental downcomer this can be written as:

$$h_{ow} = 750 \left[\frac{L_w}{\rho_L l_w} \right]^{2/3}$$

Where:

- l_w** = weir length, m,
- h_{ow}** = weir crest, mm liquid,
- L_w** = liquid flow-rate, kg/s.

Weir height

- ❖ The height of the weir determines the volume of liquid on the plate and is an important factor in determining the plate efficiency.
- ❖ A high weir will **increase** the plate efficiency but at the expense of a higher plate pressure drop.
- ❖ For columns operating above atmospheric pressure the weir heights will normally be between **40 to 50** mm is recommended.
- ❖ For vacuum operation lower weir heights are used to reduce the pressure drop; **6-12** mm is recommended.

Weir dimensions

Weir length

- A good initial value to use is 0.77, equivalent to a downcomer area of 12 per cent.
- The relationship between weir length and downcomer area is given in the following Figure .

Relation between downcomer area and weir length.

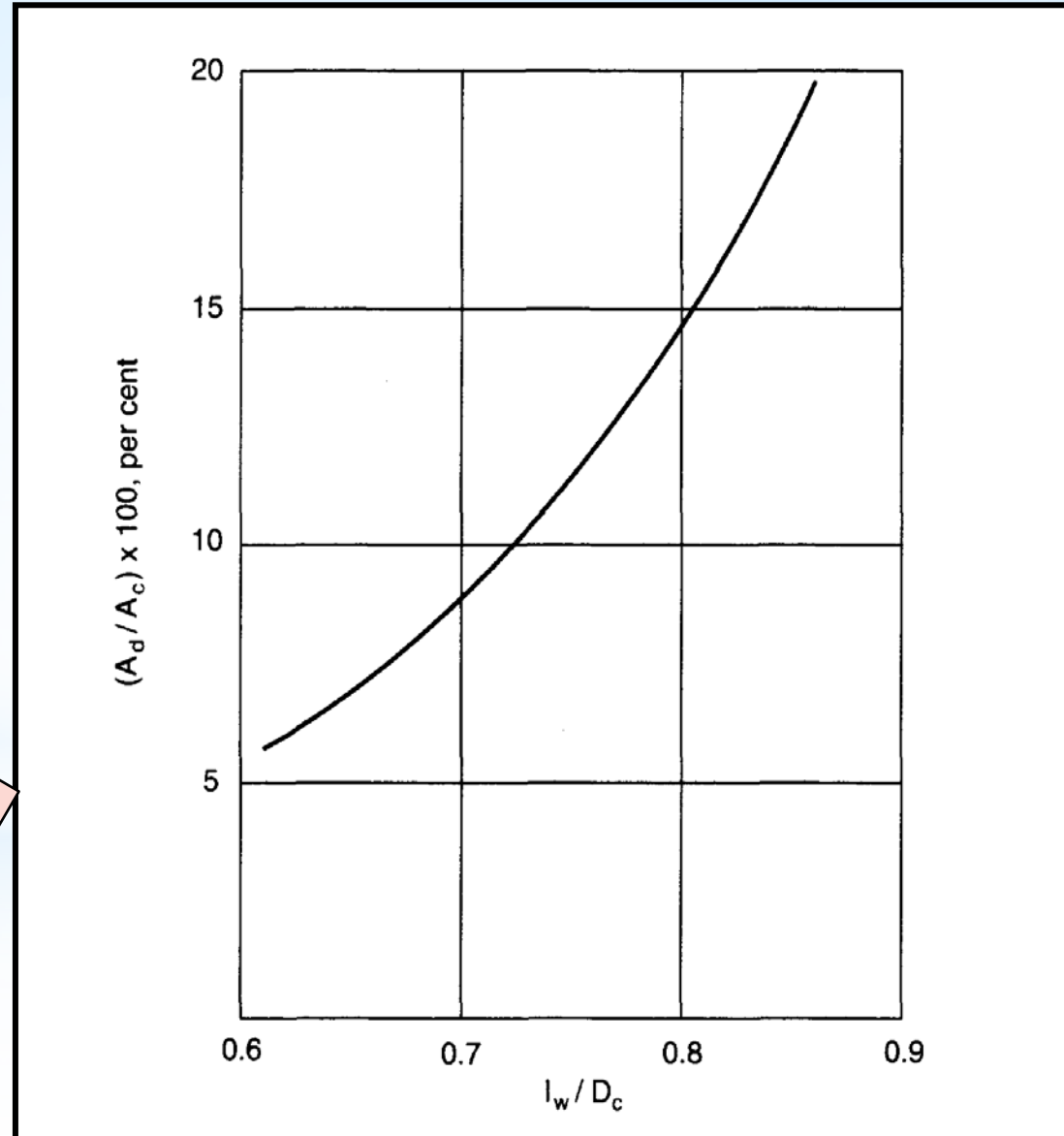

Perforated Area

Calming zones are un perforated strips of plate at the inlet and outlet sides of the plate. Recommended values are below 1.5m diameter, 75 mm; above, 100 mm.

The un perforated area can be calculated from the plate geometry.

The relationship between the weir chord length, chord height, and the angle subtended by the chord is given in the following Figure.

Figure shows the Relation between angle subtended by chord, chord height, and chord length.

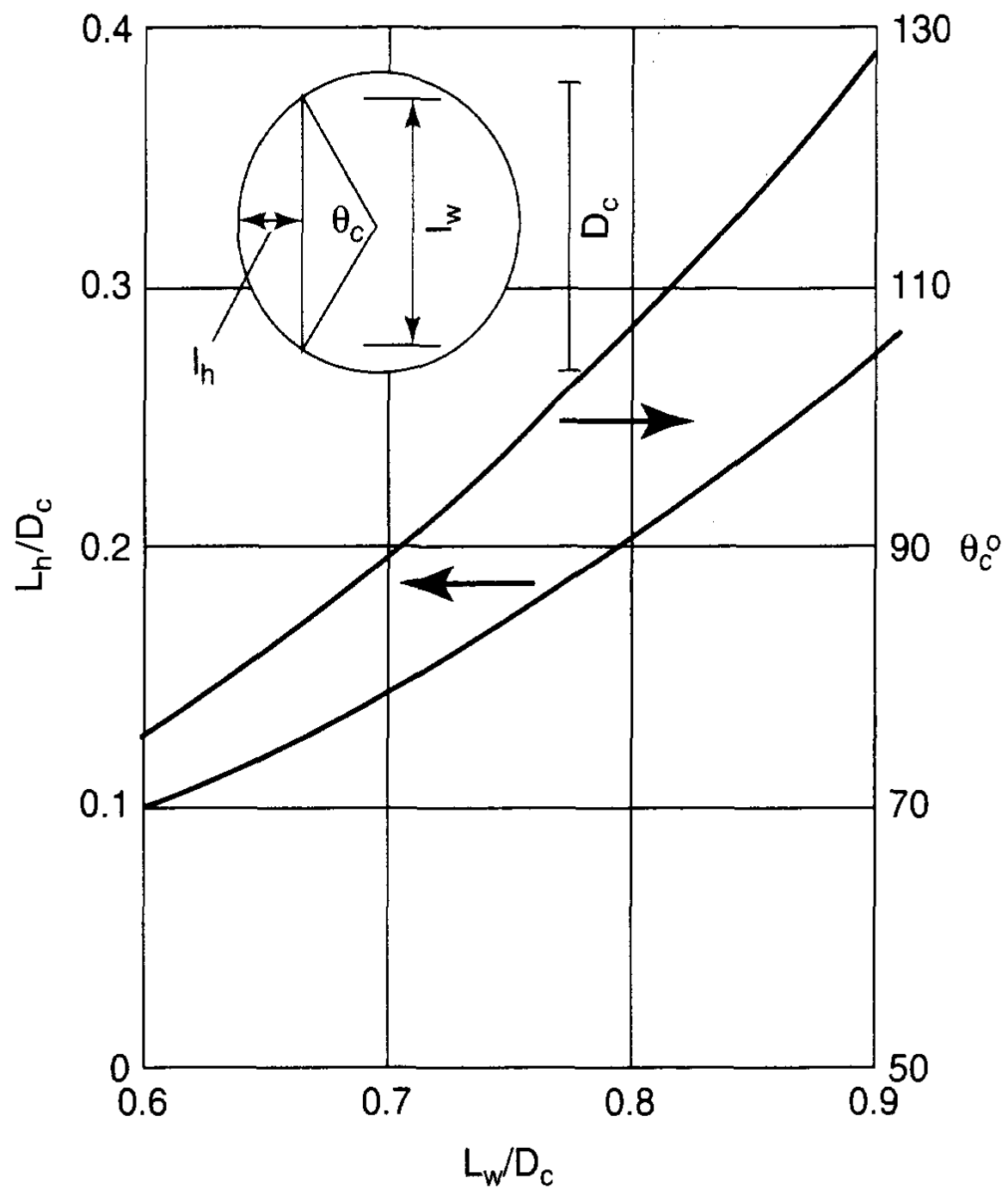

Hole Size

The hole sizes used vary from 2.5 to 12 mm; 5mm is the preferred size.

Hole Pitch

- The hole pitch (distance between the hole centers) l_p **should not be less** than **2.0** hole diameters, and the normal range will be **2.5 - 4.0** diameters.
- Square and equilateral triangular patterns are used; **triangular** is preferred.
- The total hole area as a fraction of the perforated area A_p is given by the following expression, for an **equilateral triangular** pitch:

$$\frac{A_h}{A_p} = 0.9 \left[\frac{d_h}{l_p} \right]^2$$

This equation is plotted in following Figure

Relation between hole area and pitch

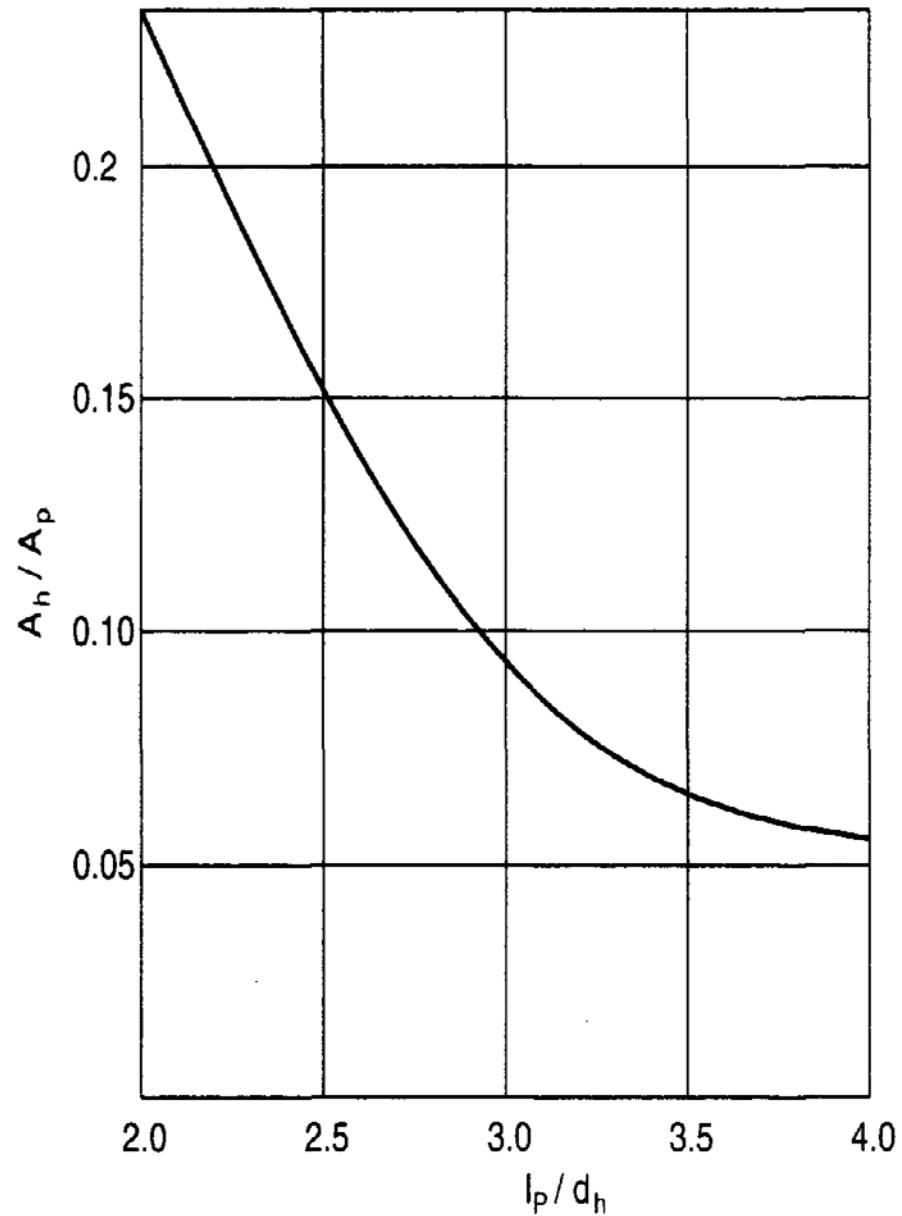

PACKED COLUMNS

- The liquid flows down the column over the **packing surface**, and the gas or vapor flows **counter-currently** up the column.

A schematic diagram, showing the main features of a packed absorption column, is given in the following figure.

- The performance of a packed column is very dependent on the maintenance of good **liquid and gas distribution** throughout the packed bed

Packed
absorption
column.

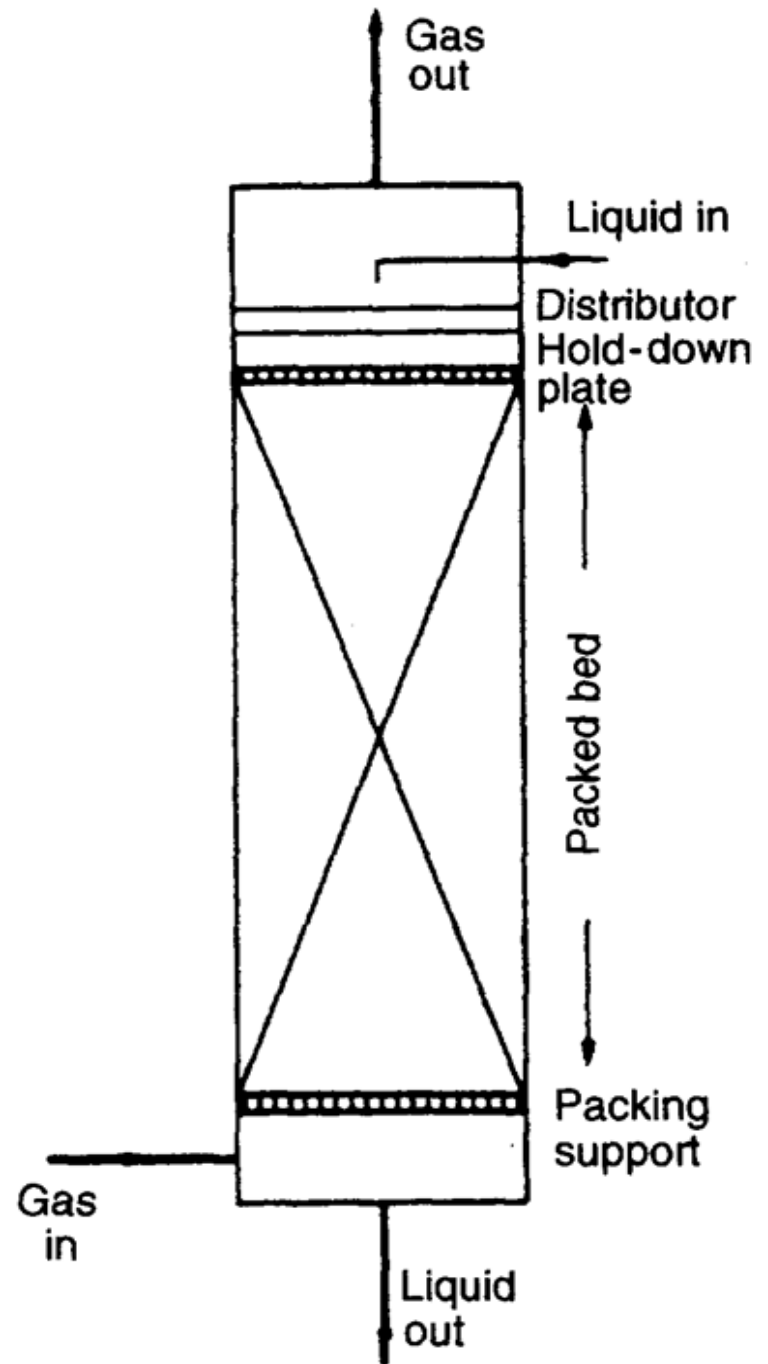

Choice of Plates or Packing

1. Plate columns can be designed to handle a wider range of liquid and gas flow-rates than packed columns.

2. Packed columns are not suitable for very low liquid rates.

3. The efficiency of a plate can be predicted with more certainty than the equivalent term for packing (height of a theoretical plate [HETP] or heights of transfer units [HTU]).

4. Plate columns can be designed with more assurance than packed columns. There is always some doubt that good liquid distribution can be maintained throughout a packed column under all operating conditions, particularly in large columns.

Choice of Plates or Packing

5. It is easier to make provision for cooling in a plate column; coils can be installed on the plates.

6. It is easier to make provision for the withdrawal of side-streams from plate columns.

7. If the liquid causes fouling, or contains solids, it is easier to make provision for cleaning in a plate column; manways can be installed on the plates. **With small - diameter** columns it may be cheaper to use packing and replace the packing when it becomes fouled.

8. For corrosive liquids a packed column will usually be cheaper than the equivalent plate column.

Choice of Plates or Packing

9. The liquid holdup is appreciably lower in a packed column than a plate column. This can be important when the inventory of toxic or flammable liquids needs to be kept as small as possible for safety reasons.

10. Packed columns are more suitable for handling foaming systems

11. The pressure drop per equilibrium stage (HETP) can be lower for packing than plates, and packing should be considered for vacuum columns.

12. Packing should always be considered for small diameter columns, say less than 0.6 m, where plates would be difficult to install and expensive.

Packed-Column Design Procedures

The design of a packed column will involve the following steps:

1. Select the type and size of packing.

2. Determine the column height required for the specified separation.

3. Determine the column diameter (capacity) to handle the liquid and vapor flow rates.

4. Select and design the column internal features: packing support, liquid distributor, redistributors.

Types of Packing

The principal requirements of a packing are that it should:

- Provide a large surface area: a high interfacial area between the gas and liquid.
- Have an open structure: low resistance to gas flow.
- Promote uniform liquid distribution on the packing surface
- Promote uniform vapor gas flow across the column cross-section.

Many diverse types and shapes of packing have been developed to satisfy these requirements.

Types of Packing

They can be divided into two broad classes:

2. Random packings: rings, saddles, and proprietary shapes, which are dumped into the column and take up a random arrangement.

1. Packings with a regular geometry, such as stacked rings, grids, and proprietary structured packings.

Types of Packing : 2- Random packings:

A- Raschig rings, as shown in Figure (a), are one of the oldest specially manufactured types of random packing and are still in general use.

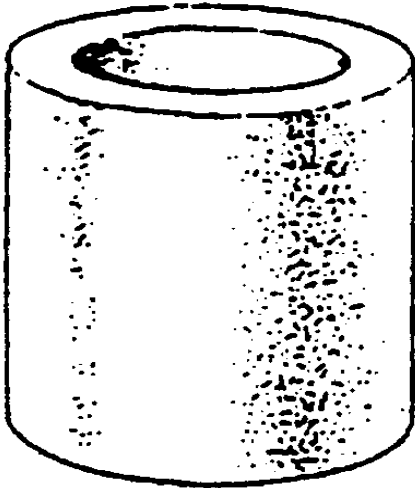

Ceramic

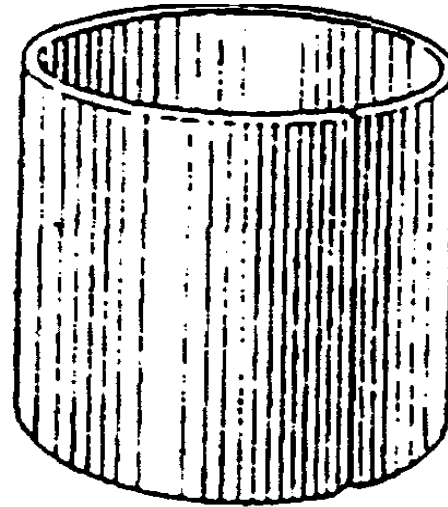

Metal

(a)

Types of Packing : 2- Random packings:

B- Pall rings, shown in Figure (b) , are essentially Raschig rings in which openings have been made by folding strips of the surface into the ring. This increases the free area and improves the liquid distribution characteristics

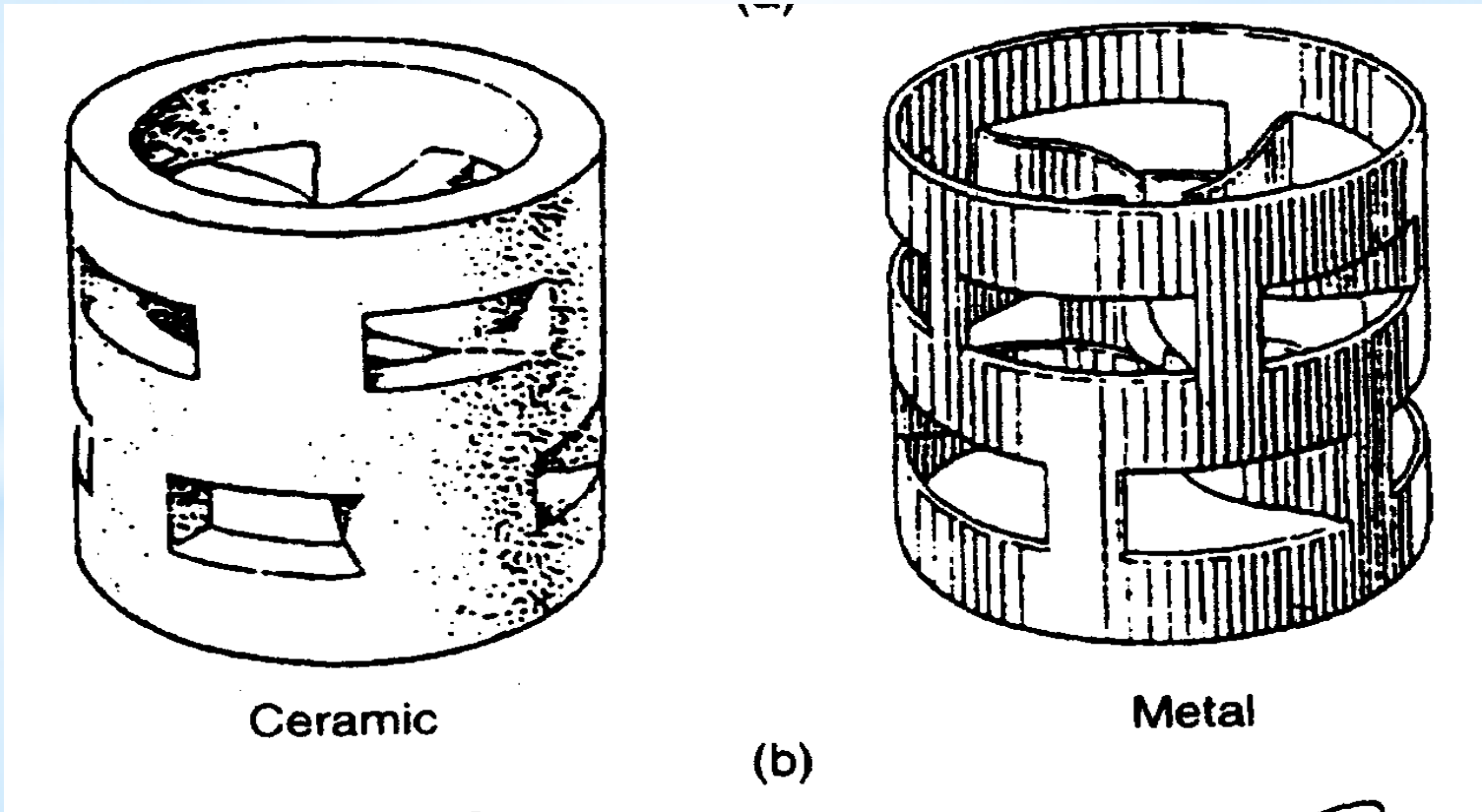

Types of Packing : 2- Random packings:

C-Berl saddles, shown in Figure (c), were developed to give improved liquid distribution compared to Raschig rings.

D- Intalox saddles, Figure (d) , can be considered to be an improved type of Berl saddle.

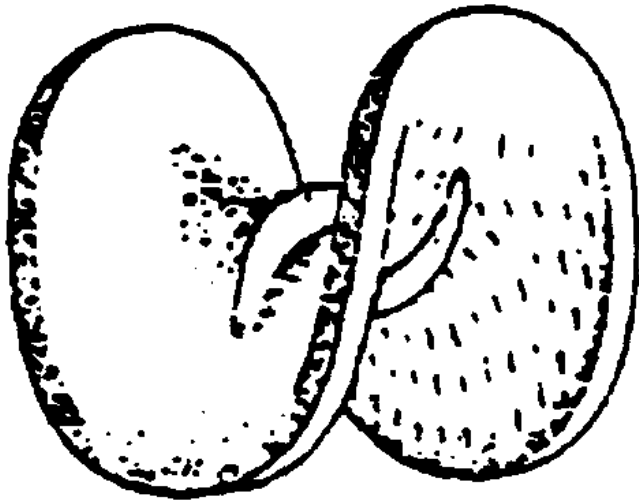

(c)

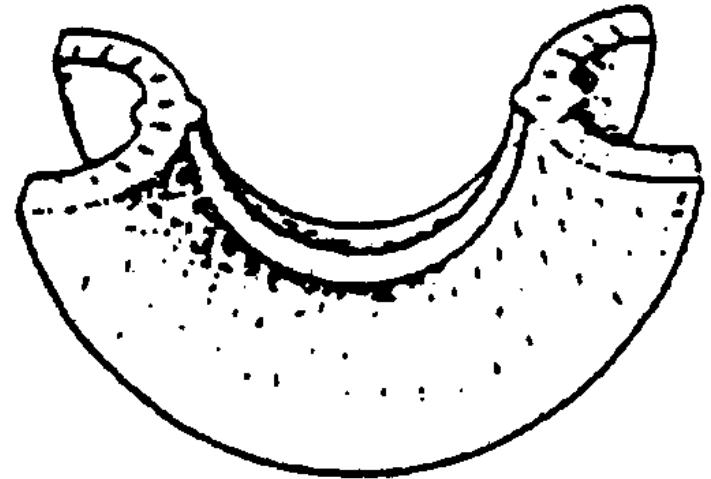

(d)

Types of Packing : 2- Random packings:

E- The Hypac and Super Intalox packings, shown in Figure (e) and (f) can be considered improved types of Pall rings and Intalox saddles, respectively.

The choice of material will depend on (1) the nature of the fluids and the (2) operating temperature.

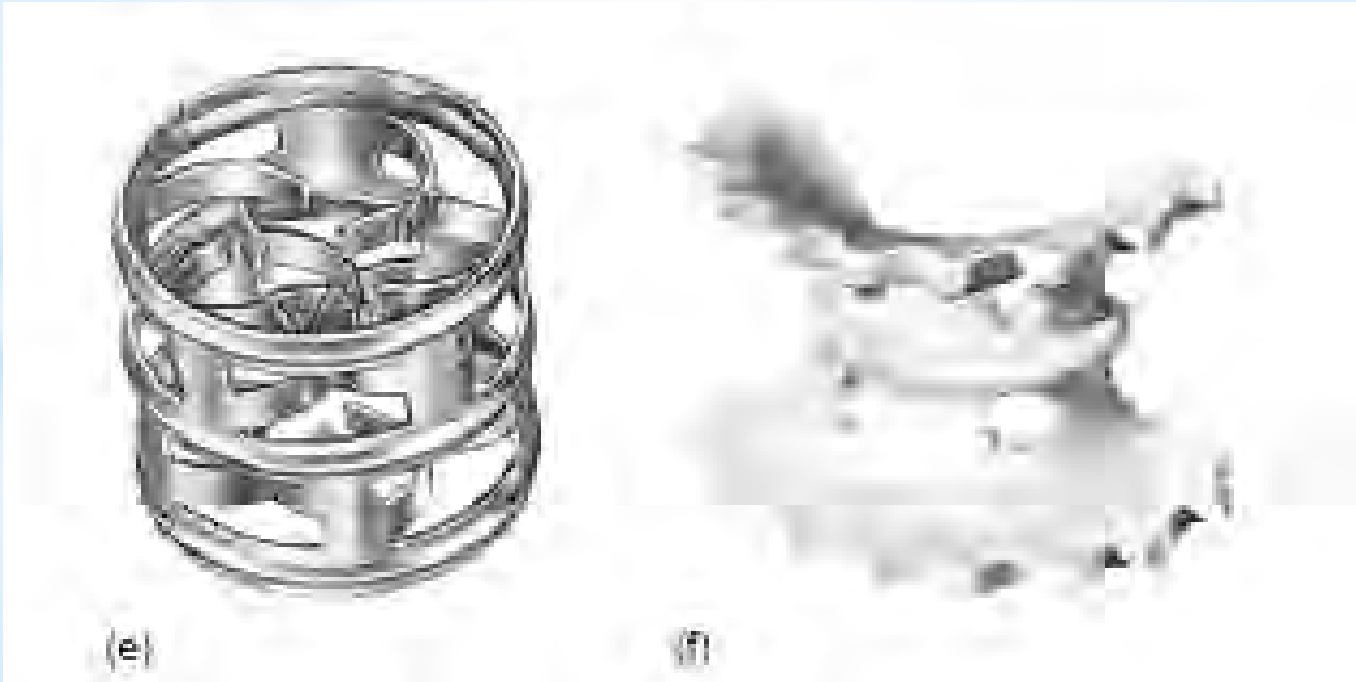

Packing Size

Recommended size ranges are:

Column Diameter	Use Packing Size
<0.3m (1 ft)	<25mm (1 in.)
0.3 to 0.9m (1 to 3 ft)	25 to 38mm (1 to 1.5 in.)
>0.9m	50 to 75mm (2 to 3 in.)

Column Diameter (Capacity)

- For random packings the **pressure drop will not normally exceed 80mm** of water per meter of packing height.
- At this value, the gas velocity will be about 80% of the flooding velocity.
- Recommended design values, mm water per m packing, are:

Absorbers and strippers 15 to 50

Distillation, atmospheric, and moderate pressure 40 to 80

The column cross-sectional area and diameter for the selected pressure drop can be determined from the generalized pressure-drop correlation given in Figure.

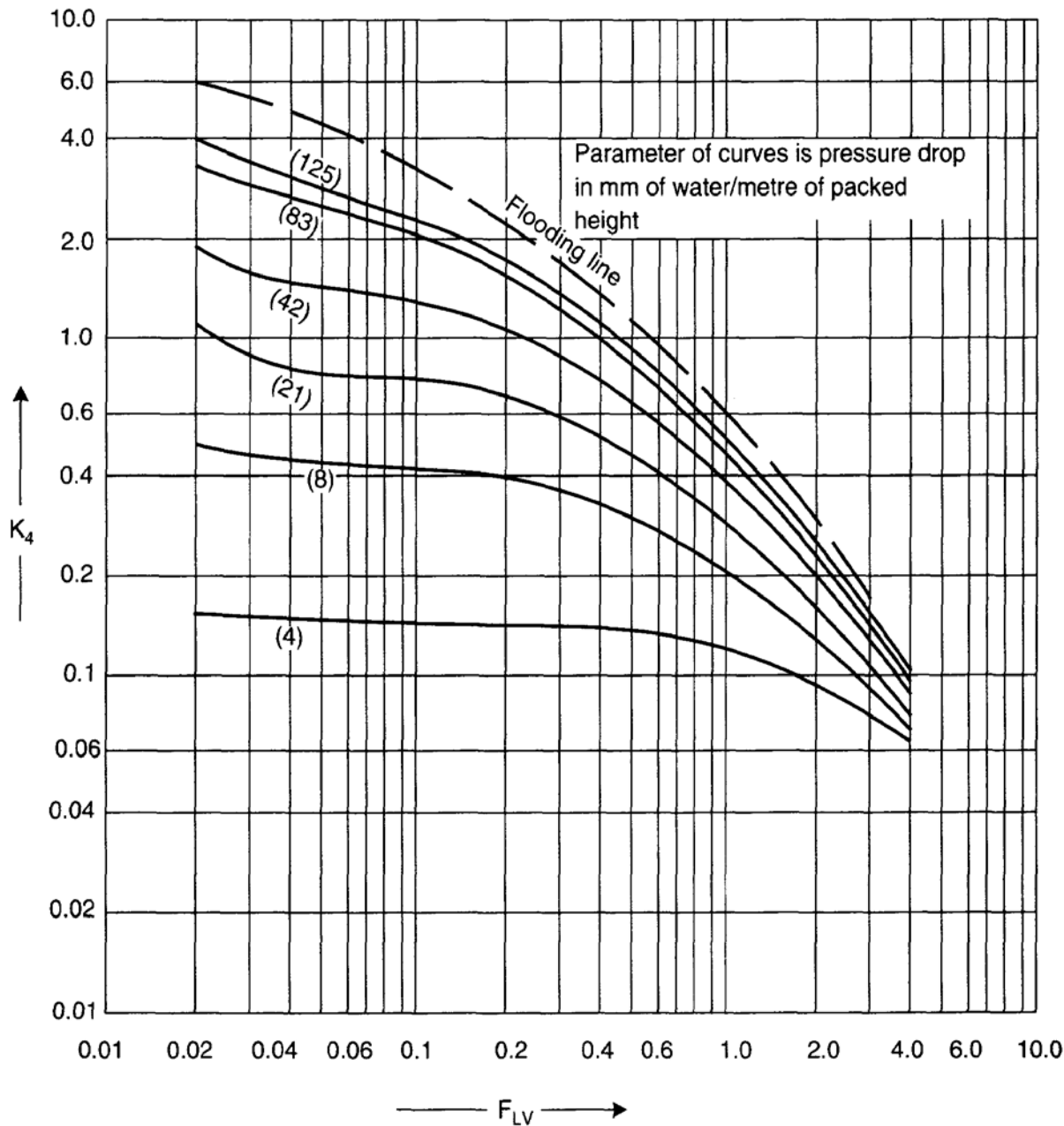

$$F_{LV} = \frac{L_W^*}{V_W^*} \sqrt{\frac{\rho_V}{\rho_L}}$$

Generalized pressure drop correlation,

The term K_4 on Figure is the function

$$K_4 = \frac{13.1(V_w^*)^2 F_p \left(\frac{\mu_L}{\rho_L}\right)^{0.1}}{\rho_v(\rho_L - \rho_v)}$$

where V_w^* = gas mass flow-rate per unit column cross-sectional area, $\text{kg/m}^2\text{s}$

F_p = packing factor, characteristic of the size and type of packing,
see Table 11.3, m^{-1} .

μ_L = liquid viscosity, Ns/m^2

ρ_L, ρ_v = liquid and vapour densities, kg/m^3

Table 11.4. Typical packing efficiencies

System	Pressure kPa	Column dia, m	Packing type	Packing size, mm	HTU m	HETP m
<i>Absorption</i>						
Hydrocarbons	6000	0.9	Pall	50		0.85
NH ₃ -Air-H ₂ O	101	—	Berl	50	0.50	
Air-water	101	—	Berl	50	0.50	
Acetone-water	101	0.6	Pall	50		0.75
<i>Distillation</i>						
Pentane-propane	101	0.46	Pall	25		0.46
IPA-water	101	0.46	Int.	25	0.75	0.50
Methanol-water	101	0.41	Pall	25	0.52	
	101	0.20	Int.	25		0.46
Acetone-water	101	0.46	Pall	25		0.37
	101	0.36	Int.	25		0.46
Formic acid-water	101	0.91	Pall	50		0.45
Acetone-water	101	0.38	Pall	38	0.55	0.45
	101	0.38	Int.	50	0.50	0.45
	101	1.07	Int.	38		1.22
MEK-toluene	101	0.38	Pall	25	0.29	0.35
	101	0.38	Int.	25	0.27	0.23
	101	0.38	Berl	25	0.31	0.31

Pall = Pall rings, Berl = Berl saddles, Int. = Intalox saddles