

Fuel Technology

INTRODUCTION

Fuel is a substance which, when burnt and reacts with oxygen or air, produces heat. The substances classified as fuel must necessarily contain one or several of the combustible elements: carbon, hydrogen, sulphur, etc.

Fuels are classified mainly in four general classes namely:

- *Fossil fuel*
- *by-products fuel*
- *chemical fuel*
- *nuclear fuel.*

The first three release heat by combustion in presence of air or oxygen. Nuclear fuels release heat by nuclear fission or fusion by converting mass into energy.

- *Fossil fuels* are those which have been derived from fossil remains of plant and animal life and are found in the crust of the earth *e.g.* coal, petroleum, natural gas etc.
- *By-product fuels* are the co-product of some regular manufacturing process and are of a secondary nature. As for example, coke oven gas and blast furnace gas are the by-product fuels in the process of coke and ironmaking respectively.
- *Chemical fuels* are of an exotic nature and normally not used in conventional processes. Examples are hydrazine (a rocket fuel), ammonium nitrate, fluorine etc.
- *Nuclear fuels* which release heat by fission are uranium, plutonium etc. and those generating heat by fusion are deuterium and ²tritium (both are isotopes of hydrogen) etc. In both the situations, the mass is converted into energy.

Fuel Technology

Depending upon the state of occurrence, the fuels are classified as solid, liquid or gaseous. Fuels in each general division are further classified as (Table 1).

- **Primary fuel** are those which occur in nature *viz.* coal, wood, petroleum, natural gas etc.
- **Secondary fuels** are those which are derived from primary fuel *e.g.* fuel oil & kerosene (derived from petroleum), Secondary fuels are further classified into

a-manufactured and b-by-product fuels.

1. **Manufactured fuels** are those which are made for some specific purpose *e.g.* coke (made for iron making), gasoline (made for internal combustion engines), producer gas (made for industrial heating) etc.

2. **By-product fuels** are those which are a co-product/side product (unavoidable product) of a regular manufacturing process *e.g.* bagasse, tar, refinery gas etc.

Table 1. gives the classified list of important fuels (excluding chemical & nuclear fuel).

General Division	Secondary Fuels		
	Primary Fuels	Manufactured	By-product
Solid	Wood Coal	Semi-coke Coke Charcoal Briquettes Pulverised Coal	Charcoal Wood refuse Bagasse Coke breeze Waste material from grain
Liquid	Petroleum	Petrol Kerosene Alcohol Colloidal fuels Fuel oil Naphtha Vegetable Oil	Tar Pitch Benzol Paper pulp mill waste
Gaseous	Natural gas	Producer gas Water gas Carburetted water gas Coal gas Oil gas Gober gas Reformed natural gas Butane Propane Acetylene Hydrogen LPG	Blast furnace gas Coke oven gas Oil refinery gas Sewage gas L.D. converter gas

Fuel Technology

Nuclear fuels are of two-types:

1. One type can release heat by its fission by neutron bombardment. Such fuels are called fissile fuel *e.g.* uranium-233, uranium-235, plutonium-239.
2. Another type of nuclear fuels release heat by fusion, *e.g.* deuterium & tritium (both are isotopes of hydrogen), hydrogen etc.

Depending upon the usage, fuels are classified as:

1. *domestic fuel,*
2. *illuminating fuel*
3. *industrial fuel*
4. *rocket fuel*

- **Domestic fuels** supply heat for cooking .
- **illuminating fuels** *e.g.* kerosene, town gas etc. supply light in darkness.
- **Industrial fuels** supply heat for process heating, steam and electricity generation etc.
- **Rocket fuels** *e.g.* hydrazine are used for producing enormous thrust for the propulsion of rocket.

As per another general classification system, the fuels which generate heat by combustion are called '*Chemical Fuels*' and the fuels which generate heat by nuclear fission or fusion are called '*Nuclear Fuels*'.

Fuel Technology

FUELS AND THEIR CHARACTERISTICS

1- Solid Fuels

Solid fuels are mainly classified into two categories, i.e. natural fuels, such as wood, coal, etc. and manufactured fuels, such as charcoal, coke, briquettes, etc. (Table.1). The various advantages and disadvantages of solid fuels are given below:

Advantages

- (a) They are easy to transport.
- (b) They are convenient to store without any risk of spontaneous explosion.
- (c) Their cost of production is low.

Disadvantages

- (a) Their ash content is high.
- (b) Their large proportion of heat is wasted.
- (c) They burn with clinker formation.
- (d) Their combustion operation cannot be controlled easily.
- (e) Their cost of handling is high.

2-LIQUID FUELS AND THEIR CHARACTERISTICS

The liquid fuels can be classified as follows:

- (a) Natural or crude oil.
- (b) Manufactured oils.

The advantages and disadvantages of liquid fuels can be summarized as follows:

Advantages

- (a) They possess higher calorific value per unit mass than solid fuels.
- (b) They burn without dust, ash, clinkers, etc.
- (c) Their firing is easier and also fire can be extinguished easily by stopping liquid fuel supply.
- (d) They are easy to transport through pipes.
- (e) They can be stored indefinitely without any loss.
- (f) They are clean in use and economic to handle.
- (h) They require less excess air for complete combustion.
- (i) They require less furnace space for combustion.

Fuel Technology

Disadvantages

- (a) The cost of liquid fuel is relatively much higher as compared to solid fuel.
- (b) Costly special storage tanks are required for storing liquid fuels.
- (c) There is a greater risk of fire hazards, particularly, in case of highly inflammable and volatile liquid fuels.
- (d) They give bad odour.

3-GASEOUS FUELS AND THEIR CHARACTERISTICS

Gaseous fuels occur in nature, besides being manufactured from solid and liquid fuels. The advantages and disadvantages of gaseous fuels are given below:

Advantages

following advantages over solid or liquid fuels:

- (a) They can be conveyed easily through pipelines to the actual place of need, thereby eliminating manual labour in transportation.
- (b) They can be lighted at ease.
- (c) They have high heat contents and hence help us in having high temperatures.
- (d) They can be pre-heated by the heat of hot waste gases.
- (e) Their combustion can readily be controlled for change in demand like oxidizing or reducing atmosphere, length of flame, temperature, etc.
- (f) They are clean in use.
- (g) They do not require any special burner.
- (h) They burn without any soot, or smoke and ashes.
- (i) They are free from impurities found in solid and liquid fuels.

Disadvantages

- (a) Very large storage tanks are needed.
- (b) They are highly inflammable, so chances of fire hazards in their use is high.

Fuel Technology

ORIGIN OF COAL

Coal is a complex mixture of plant substances altered in varying degree by physical and chemical processes. These processes which changed plant substances into coal has taken million of years and has been accomplished by bacteria, heat and pressure inside the earth's crust.

Different stages in the formation of coal from plant/vegetable debris (called peat to anthracite series) is as follows:

Plant/vegetable debris.peat → lignite → sub-bituminous coal → bituminous coal → semi-anthracite → coal anthracite → coal graphite.

In this series from peat to anthracite; each member is more mature or *of* higher 'rank' than the one which precedes in the series. Thus anthracite coal is of higher rank than bituminous coal. Bituminous coal is of higher rank (i.e., more mature) than lignite. With the progress of coal forming reaction, moisture and oxygen content reduces and percentage of carbon increases.

Classification of Coal

Coals are classified based on various parameters like proximate analysis, calorific value maturity (rank), ultimate analysis, caking properties etc.

Their classification is only described in the following:

1- **Regnault s classification:** this was the first satisfactory classification given by Regnault in 1835 which is based **ultimate analysis of coal**.

2- **Regnault Gruner s classification:** was modified in 1874 by Gruner in which numerical limits were given for carbon, hydrogen and volatile matter to the higher rank coals defined by Regnault.

3- **Brame s classification:** it is modified and extended form of Gruner's classification which includes all the coals.

Fuel Technology

'Table Brame's Classification (i.e. Modified Gruner's Classification) of Coals

No. of class	Name of Class	Carbon	Hydrogen	Oxygen	Volatile matter
I	Lignituous	75-80	4.8-5.5	12-20	35-47
II	Ligno-bituminous	78-84	4.5-6	8-13.5	35-45
III	Bituminous Coals	82-86	5-6	6-12	30-40
IV		82-86	4.5-5.5	5-9	30-40
V		85-89	4.5-5.5	4-7.5	20-30
VI	Semi-bituminous	89-92	4-5	2-4.5	13-20
VII	Semi-anthracite	91-93	3-4.5	3-5	8-13
VIII	Anthracite	> 92.5	< 4	< 3	< 8

4- Feazer` s classification: depending on the ratio of fixed carbon to volatile matter.

5- National Coal Borad (NCB) Classification: is based on two parameters:

- a- The percentage of volatile matter on the dry mineral matter free basis.
- b- The caking power of clean coal (containing < 10% ash) as indicated by Gray-King coke type.

Composition of Coals

Composition of coal is expressed in terms of its:

1-Proximate analysis

2-Ultimate analysis.

Proximate analysis of coal means determining the percentage of moisture, volatile matter, fixed carbon and ash. Proximate analysis with sulphur content and heating value of coal helps in deciding the mode of utilisation of a particular coal.

Fuel Technology

Ultimate analysis of coal: means determining of its total carbon, hydrogen, oxygen, nitrogen, sulphur and ash content. It gives analysis in terms of the elementary constituents and is helpful in combustion calculations for design of furnaces and its auxiliaries.

The changes in average composition from:

Wood → peat → lignite → bituminous coals → anthracite

Units Fundamentals, Definitions

1. Rank of coal (which is the most important variable in the nature of coal) is determined by volatile calorific value and carbon content of coal, singly or in combination.

2-Coalification (or metamorphism).

The process of conversion of lignite to anthracite is called coalification or metamorphism of coal.

3-Carbonisation of Coal.

Heating of coal in absence of air at high temperature to produce a residue coke, tar and gas is called its carbonization.

4-Gasification of Coal.

Heating of coal with insufficiently less quantity of air plus steam to produce a gas rich in CO and H₂ is called its gasification. This is done to produce gaseous fuel from solid and liquid fuel.

5-Combustion. It is an exothermic chemical reaction of a fuel with oxygen or air at high temperature to liberate heat.

Fuel Technology

6-Calorific value. The quantity of heat (kcal) liberated by the combustion of unit quantity of fuel is called its calorific value. Unit of calorific value is kcal/kg for solid and liquid fuels and kcal/Nm³ for gaseous fuels.

Calorific value or higher heating value at constant volume is the quantity of heat liberated by combusting the fuel at constant volume in oxygen saturated with water vapour, the original material and final products of combustion being at a reference temperature (25°C) and the water obtained from the fuel being in the liquid state.

Gross calorific value at constant pressure implies that the combustion takes place at constant pressure and not at constant volume. In the laboratory determinations, solid and liquid fuels are burnt at constant volume and gaseous fuels are burnt at constant pressure. In the ovens and furnaces, however, the combustion takes place at constant pressure.

The following formula is used in calculating the net calorific value from gross calorific value of solid and liquid fuels approximately:

$$C_N = C_G - 9H \dots \dots \dots (1)$$

Where C_N and C_G = net and gross calorific value in Kcal/Kg, respectively, and H = percentage of hydrogen of coal, including hydrogen of moisture and of water of hydrogen of minerals.

For gaseous fuel, the formula is:

$$C_N = C_G - 4.7V$$

Where C_N and C_G = net and gross calorific value in Kcal/Nm³, respectively, and V = volume percentage as H_2 of total hydrogen of

Fuel Technology

gaseous fuel, including the hydrogen obtainable from other combustible components.

Coal Preparation:

There are three methods as following:

- 1- **Coal Preparation –Grading and Crushing:** the object of coal preparation is to provide each user with fuel of optimum specification for the appliance used.

Procedure:

Coal Preparation includes some or all of the following:

- Separation of coal types at the coal face e.g. into Hards and Brights.
- Screening or grading into fraction of different size.
- Hand- picking of large sizes to remove separate lumps of impurity.
- Crushing of larger sizes to provide the smaller size mostly required by industry.
- Cleaning to remove inorganic impurities when low- ash coal is required.
- Drying, when small- sized coals are washed to remove impurities.
- Blending to modify the properties of a coal.

2-Coal Preparation- Mechanical Cleaning Theory

To reduce the amount of ash formed from the coal in combustion appliance to an acceptable degree, in an economical manner.

3-Coal Preparation –Mechanical cleaning- Types of plants

- Dry- cleaning Processes.
- Wet - cleaning Processes.

Fuel Technology

Washing of coal

Most of the coals when mined contain impurities associated with which must be removed before the coal is used. Impurities are removed from coal by washing.

Coal contains two types of impurities:

-Fixed or inherent impurities: it is derived from coal forming plant and cannot be separation from coal by washing. A new process developed at central fuel research institute (CFRI), called oil agglomeration technique which consists mainly of leaching of coal impurities by petroleum oil can to some extent remove these impurities. Inherent mineral matter in coal is <3%.

- Free impurities: these are impurities adhering to the surface of the coal and comprise mainly of dirt band and rock particles which can be removal by washing of coal.

Nature of impurities present in coal are of the following: Residual inorganic matter of coal forming plants

- Mineral matter washed or blown into the coal forming mass during the period of its formation.
- Pyrites (FeS_2) formed by the reaction of iron sulphate with coal forming matter.

Objective of coal washing:

- 1- Reduces its ash content.
- 2- Reduces its sulphur and phosphorous contents which are detrimental particularly to metallurgical coals.
- 3- Increases its heating value.
- 4- Improves its coking properties.
- 5- Increases the fusion point of its ash by removing alkali chlorides (which is responsible for lowering the fusion point).
- 6- Reduces its clinkering tendency.
- 7- Increases its efficiency in use.

Fuel Technology

Advantage of Clean (Washed) Coal:

- Higher efficiency of utilisation.
- Less clinkering trouble in furnaces and gasifier.
- Lesser content of S, P, CI, and other harmful elements.
- improved coking properties.
- Economy of transport and storage.
- reduces its ash content.

Types of Coal Washing Processes

They are of following three types:

1. Gravity Separation method:

- Wet processes.
- Dry processes.

2. Float and sink method

Fine solids and water floatation (Sand Magnetite and other materials)

3. Froth floatation method.

Modern Trends in Coke Making

Modern trends in coke making aim at reducing specific heat consumption in coke making by way of fuel economy techniques and high productivity of the coke oven.

Some of the methods of economising fuel consumption in coke making are discussed below:

1-Washing of coal. Ash content in the coke can be reduced by suitably washing the coking coal.

Fuel Technology

2-Blending of coal. Highly coking coals are always blended with non-coking coal; anthracite, coke breeze, medium coking coal, etc. to check its excessive swelling during carbonisation as it might damage the coke oven walls. Blending of coal improves the yield of uniform coke.

3-Preheating of coal charge. Preheating of coal increases its bulk density resulting in increased productivity of the oven besides lowering the time of carbonisation.

4-Addition of coking agents. Low coke ability of some weakly coking coal can be improved by the addition of coking agent like asphalt, tar, pitch etc. but the presence of sulphur in the coking agent.

5-Formed coke. Formed coke is made from low rank, highly volatile non-coking coal with low swelling number. It is carbonised at a low temperature of 500°C to produce char either in a fluidised bed where rapid heating of finely crushed charge is possible. The final product is called formed coke.

6-Dry-Quenching of coke. Dry quenching of coke aims at recovering the sensible heat of the hot coke.

7-Stamped charging of coal. Stamp charging is a means of increasing the bulk density of coal.

The Combustion of Coal

Oxidation is most rapid in a freshly mined coal at higher temperatures. Some facts in this regard have been established and are given below:

-Oxidation of coal is a continuous process depending upon the time and conditions.

-The rate of oxidation increases with increasing temperature and decreasing size of coal particles.

Fuel Technology

-The external conditions which cause initial attainment of critical temperatures are:

1-External source of heat such as sun's rays, nearby steam pipes, furnace flues etc.

2-Fineness of size of coal which gives an increased surface area to come in contact with free air (Oxygen).

3-Coals with high moisture and high oxygen content have relatively low critical temperatures.

Uses of Coal

Coal is used for:

- Directly burning and getting heat.
- Generating steam for producing electricity (nearly 0.5 kg of coal is burnt to generate 1 KWh of electricity).
- Driving railway locomotives.
- Manufacturing coke and coal gas (e.g. coke oven gas, producer gas, water gas etc.).
- Manufacturing synthetic liquid fuels.
- Gasification to produce nitrogenous fertilizer from synthesis gas.

Uses of Coal Chemicals

Coal chemical recovered from coke oven gas in by-product plant are subjected to various uses. Important uses of some of the chemicals are described below.

1. Clean Coke Oven Gas.

It is a fuel for steel plant furnaces mainly. Besides it is a source of H₂ for ammonia production.

Fuel Technology

2. Benzol.

It is used for the manufacture of photographic material as solvent, for rubber manufacture. Benzol is also a source of benzene, toluene and xylene which are obtained by its distillation and are valuable chemicals.

3. Tar.

It is used

- for road making purposes
- as a fuel in furnaces
- for recovering various chemicals by its distillation.

3.Pitch.

It is used:

- as a fuel in furnaces.
- for making carbon electrodes.
- for road making purposes.

4. Creosote.

It is used as a fuel after mixing with pitch. The fuel is then called pitch-creosote mixture (PCM).

5. Phenol.

It is used

- for making the plastic, phenol-formaldehyde and is used as an electrical insulating material.
- for the manufacture of perfumes, plasticisers and detergents.
- for making medicines like aspirin.

Fuel Technology

6. Naphthalene.

It is used for manufacture of Beta-naphthol which is used for making dyes and perfumes.

7. **Pyridine.** It is used for separation of various chemical products (as it forms azeotropes with water), for the manufacture of colouring substances and also for medicinal purposes.

8. **Benzene.** It is used for

-for making detergents.

-for making nylons.

9. **Toluene.** It is used

-for making dyes, plasticiser, phenol, benzoic acid, benzene etc.

-as a solvent and diluent in coatings.

-for making the explosive 'Trinitrotoluene' (TNT).

10. **Xylene.**

It is used as a solvent for paints etc.

Fuel Technology

Coal Tar Distillation

Coal tar is a black to brown oily and viscous fluid of characteristic odour produced during high or low temperature carbonisation of coal during coke manufacture.

Tar produced during low temperature carbonisation of coal (at 700 °C) is called low temperature tar whereas that produced during high temperature carbonisation (at 1100°C) is called high temperature tar.

-**Low temperature tar** its yield is about 10% of dry coal. It is a brown colour oily liquid having very low viscosity, hence flows readily. It is paraffinic in nature.

Its typical ultimate analysis is:

C = 84%	H = 8%	N = 1%
S = 0.5%		O = 6.5%

It contains very less free carbon (about 3%).

-**High temperature tar** It is a thick, high viscosity, black coloured liquid with an aromatic nature. It contains more amount of useful aromatics like phenol, naphthalene, cresote, anthracene, benzol, pyridine etc. Its free carbon content is high (10%) and the yield is lower (3% dry coal) as compared to low temperature tar.

Typical analysis of H.T. tar is

C = 90.5%	H = 5.5%	N = 0.9%
S = 0.8%	O = 2.3%	

Fuel Technology

Distillation of Tar:

Tar contains around 300 identified chemicals. Hence, to recover economically some of these chemicals and to produce better fuel from tar, it is distilled. The main fraction of tar (which are recovered by distillation) their constituents, yield and boiling ranges are given in table:

Table Products of Tar Distillation

Fractions	Boiling range , °C	Yield, weight%	Main constituents of the fractions
Light oil	< 170	2-4	Benzol, naphtha and phenol
Middle (or carbolic) oil	170-230	5-7	Phenol, tar acids, heavy naphtha, naphthalene and pyridine
Heavy (or creosote) oil	230-270	15-25	Impure naphthalene and creosote oil
Anthracene oil	270-350	14-17	Anthracene and wash oil
Pitch	Residue	60-70	—

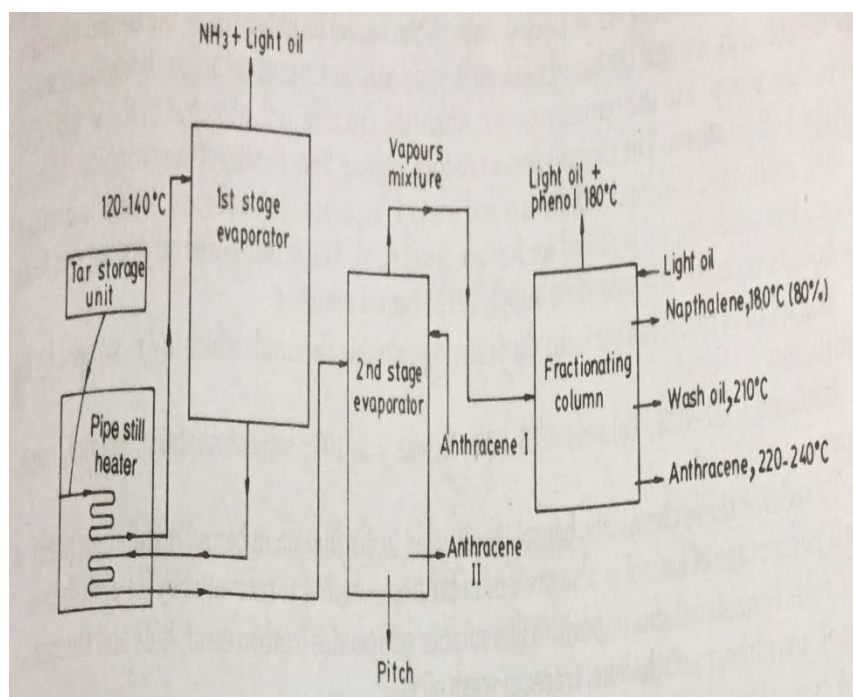

Flow Diagram of a typical tar distillation plant

Fuel Technology

Coal Gasification

Heating of coal with insufficiently less quantity of air plus steam to produce a gas rich in CO and H₂ is called its gasification. This is done to produce gaseous fuel from solid fuel.

The total coal gasification in single stage (using processes like Lurgi process) maximizes the conversion of coal into gaseous fuel and minimizes the tar formation. The gasification efficiency of these processes are very high and they are suitable for a wide range of feed material. The gases produced by the gasifier are mainly used as a fuel and a source of synthesis gas (hydrogen rich) for ammonia making in fertilizer plants.

Typical composition of Lurgi gas: cleaned and CO₂ free gas from oxygen and steam blown Lurgi generator is of following composition:

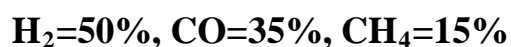

Liquefaction of Coal (Fischer- Tropsch Process)

1. The raw material is the hard coke which is converted into a mixture of carbon monoxide and hydrogen by passing steam over red hot coke (water gas reaction):



2- Carbon monoxide is removed by converting it into carbon dioxide which is obtained by passing the water gas with extra steam over a promoted reduced iron oxide catalyst at 450°C.

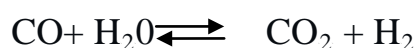

3- The synthesis gas is passed at atmospheric pressure over a cobalt-thorium oxide catalyst at 180-200°C. The reaction products are predominantly straight chain paraffins and olefins, the following equations:

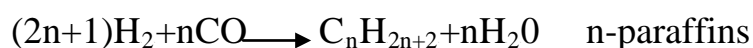

Fuel Technology



4-The original catalysts for Fischer-Tropsch process was cobalt. Now cheaper iron-oxide catalysts are used. All the reactions are highly exothermic, hence control of reactor temperature is critical.

Operating Conditions of Fischer-Tropsch Reactors (High Pressure)

<i>Process</i>	<i>Temperature, °C</i>	<i>Pressure, atm</i>	<i>Catalyst</i>
Arge fixed bed	Up to 270	25-30	Precipitate Iron
Kellogg fluidized bed	300-340	25-30	Millscale or similar iron oxide

Fuel Technology

Liquid Fuel/ Petroleum Petroleum Assay

Petroleum

Petroleum (or rock oil) is a naturally occurring brown to black oil comprising mainly of hydrocarbons found under the crust of the earth on shore or off shore. It is obtained, from the ground either by natural by drilling wells to various depths. Either petroleum oil flows out itself due to underground gas pressure or these are mechanically pumped out.

Modern Theory. According to modern views, petroleum is believed to be formed by the decay and decomposition of:

- Marine animals
- Vegetable organism of the pre-historic forests, *i.e.* it is of animal as well as of plant origin.

It is thought that due to some upheavals or earthquakes, these prehistoric forests, and sea animals got buried under the crust of earth. Due to action of prolonged action of high temperature and pressure in the interior of earth for ages, the biological matter decomposed into petroleum.

Fuel Technology

Difference between Origins of Petroleum Oil and Coal

- Petroleum oil was formed mainly from sea plants and animals decaying under strongly reducing conditions while the coal was formed mainly from land plants decaying under mildly reducing conditions.
- Coal seams remained static where formed/deposited while oil can migrate under the effects of pressure and temperature so that the location of the existing deposits may not be the location of the initial accumulation of oil forming debris. The source rock is sedimentary and mainly or entirely of marine origin.

Composition of Petroleum.

Atypical composition (by weight %) of petroleum is given below

Carbon = 84-87%	Hydrogen = 11-15%	Sulphur = 0.1-3%
Nitrogen = 0.1-1.5%	Oxygen = 0.3-1.8%	

The principal components of petroleum are hydrocarbons (paraffins, naphthenes, aromatics, olefins etc.), small amounts of sulphur, nitrogen & oxygen compounds as impurities and some inorganic compounds & metals (vanadium and platinum in traces). Sulphur compounds found in petroleum are hydrogen sulphide, thiophenes, mercaptans. Oxygen occurs in combined form in alcohols, phenols, resins and organic acids present in petroleum. Nitrogen compound include pyridines, etc. Inorganic compounds present in petroleum are salt, clay and sand etc.

Fuel Technology

Typical properties of crude oil:

Specific gravity = 0.80 - 0.95, viscosity at 37.8°C = 2.3 - 23 cst carbon/hydrogen ratio = 6 - 8, pour point = 18 - 30°C , wax content = 6 -12%, flash point = 15 - 27°C water content = 0.1 - 1.5% , Salt content = 1.5 - 8%, Ash content = 0.004 - 0.006%.
--

Production of Petroleum

Petroleum almost always occurs along with gas called natural gas. After drilling in the crust of earth both natural gas and oil flow up through pipe under pressure initially. When the oil pressure decreases, then the residual oil is either sucked by a pump or pressure is created by injecting compressed gas or high pressure water through a pipe bored by the side of oil delivery pipe so that it can flow out. When the oil well contains both oil and gas it is called (**wet well**) and if it contains only gas then it is called a (**dry well**).

A sketch of typical oil pool formation inside the crust of earth is given in Fig.1. Hard cap rock and hard rock at the bottom, both are impermeable to oil and gas. Geological studies indicates that petroleum was not formed in the pools where it is found today.

Fuel Technology

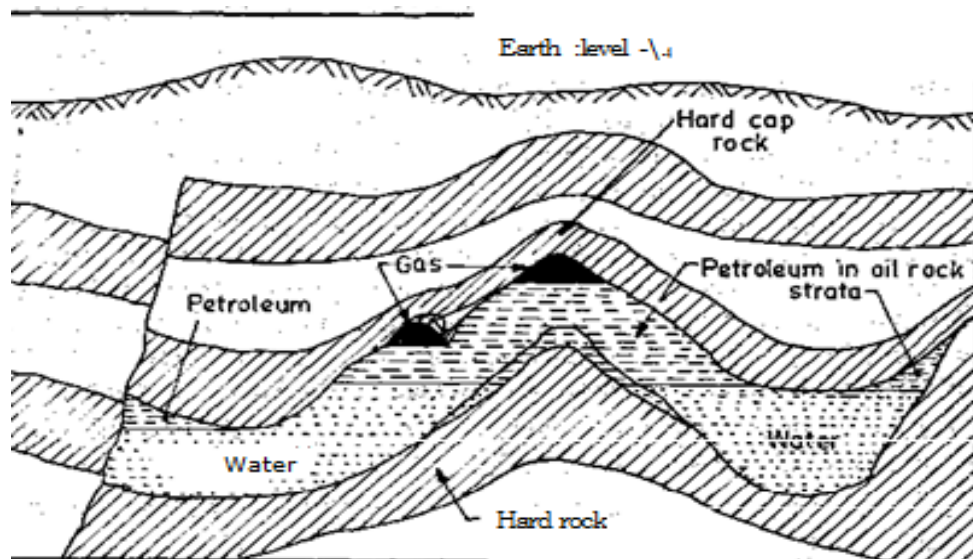

Fig.1. Typical oil-pool formations. In the centre, pool water has forced the petroleum and gas up into a dome, or anticline, in the porous oil rock layer. Hard cap rock prevents the escape of the oil. A fault, at the left, or a stratigraphic.

Pre-Treatment of Oil at Oil Field before Refining

Oil and gas when they come out of oil field are separated. The natural gas is compressed to liquify it which is used for heating of domestic and industrial ovens. Petroleum oil is made free of:

- Water,
- Sediments and
- Salts present in it.

It is then made free of some dissolved gases into it by the process called '*stabilisation*'. It is then sent to oil refinery _ for separation into various petroleum products by distillation mainly and auxiliary operations.

Fuel Technology

Crude oil as it comes out of well may contain up to (25%) water, salts ($MgCl_2$, $CaCl_2$, $NaCl$ etc.) up to 2000-5000 (mg/litre) and sediments up to (1-1.5%). For refining crude oil, the salt content in it should be < 50 mg/litre and Water $< 0.3\%$. Excessive water in crude requires extra heat for its distillation, increases its cost of transportation, forms emulsion which absorb materials like resin (hence emulsion breakers are to be used).

Salt in crude oil causes:

- scaling
- corrosion
- reduces heat transfer co-efficient during its processing.

Sediments present in crude causes:

- erosion
- scaling.

In mechanical method of separation of impurities from crude oil, it is subjected to centrifuging, filtration and settling after heating it to $120-160^\circ C$ at 6-8 atm. pressure. In physico-chemical method, emulsion breakers are added. But they are costly and cause corrosion & sludge formation.

Stabilisation of Crude Oil

Removal of dissolved gases from crude oil by heating it is called its stabilisation. Gas accompanied with crude oil must be removed to avoid breathing loss (loss of gasoline, if gas is not removed from oil during prerefining). Breathing loss occurs due to changes of humidity of ambient air and day and night temperature change also during emptying and filling of crude tanker.

Fuel Technology

Classification of Petroleum

Depending on the nature of hydrocarbons present in it, crude petroleum oil is classified as

- paraffin base,
- naphthene base,
- asphalt base,
- mixed base.

Paraffins: Paraffins refer to alkanes such as methane, ethane, propane, n and iso butane, n and iso pentane. These compounds are primarily obtained as a gas fraction from the crude distillation unit.

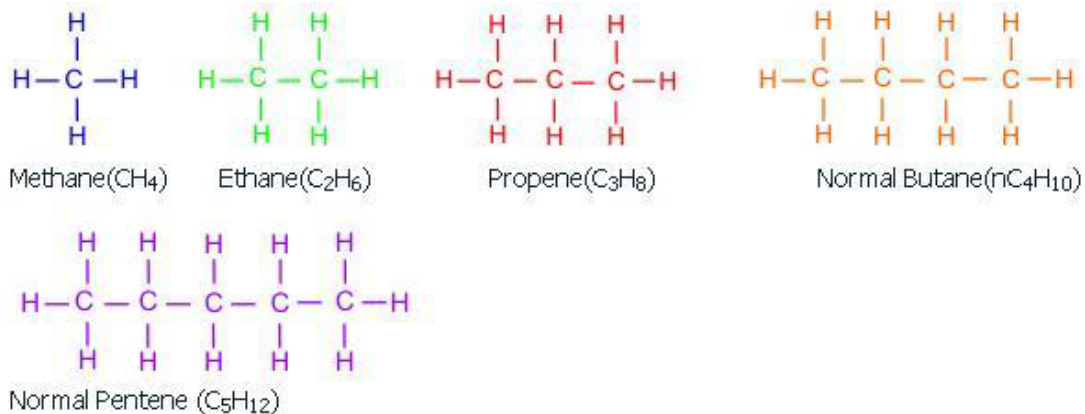

Olefins: Alkenes such as ethylene, propylene and butylenes are highly chemically reactive.

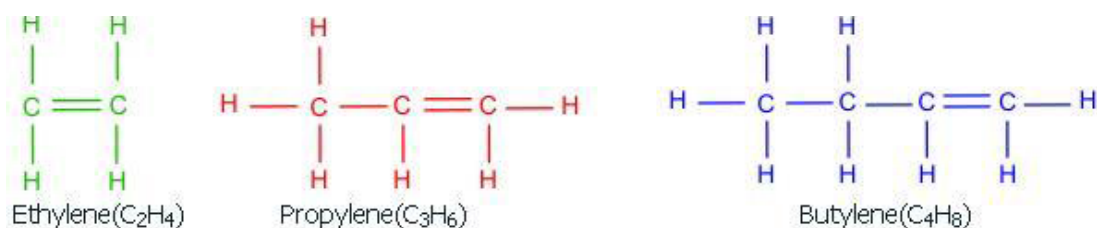

Fuel Technology

Naphthenes: Naphthenes or cycloalkanes such as cyclopropane, methyl cyclohexane are also present in the crude oil. These compounds are not aromatic and hence do not contribute much to the octane number. Therefore, in the reforming reaction, these compounds are targeted to generate aromatics which have higher octane numbers than the naphthenes.

Aromatics: Aromatics such as benzene, toluene o/m/p-xylene are also available in the crude oil. These contribute towards higher octane number products and the target is to maximize their quantity in a refinery process.

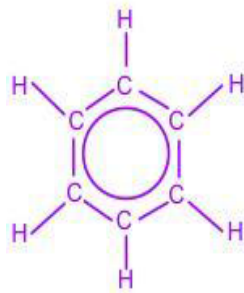

Benzene(C₆H₆)

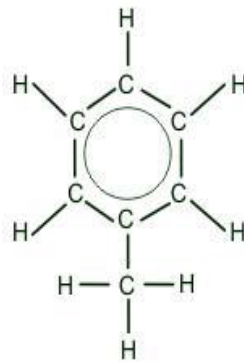

Toluene(C₇H₈)



Para-X ylene(C₈H₁₀)

Organic sulphur compounds: Not all compounds in the crude are hydrocarbons consisting of hydrogen and carbon only. Organic sulphur compounds such as thiophene, pyridine also exist in the crude oil. The basic difficulty of these organic sulphur compounds is the additional hydrogen requirements in the hydrotreaters to meet the euro III standards.

Fuel Technology

Oxygen containing compounds: These compounds do not exist 2 % by weight in the crude oil. Typical examples are acetic and benzoic acids. These compounds cause corrosion and therefore needs to be effectively handled.

Resins: Resins are polynuclear aromatic structures supported with side chains of paraffins and small ring aromatics. Their molecular weights vary between 500 – 1500. These compounds also contain sulphur, nitrogen, oxygen, vanadium and nickel.

Asphaltenes: Asphaltenes are polynuclear aromatic structures consisting of 20 or more aromatic rings along with paraffinic and naphthenic chains. a crude with high quantities of resins and asphaltenes (heavy crude) is usually targeted for coke production.

Crude Oil Properties (Petroleum Assay)

Important Characterization Properties

Numerous important feed and product characterization properties in refinery engineering include:

- API gravity
- Watson Characterization factor
- Viscosity
- Sulfur content
- True boiling point (TBP) curve
- Pour point
- Flash and fire point
- ASTM distillation curve
- Octane number

1. **API gravity** API gravity of petroleum fractions is a measure of density of the stream. Usually measured at 60 °F, the API gravity is expressed as:

$$\text{API}^\circ = 141.5/\text{specific gravity} - 131.5$$

where specific gravity is measured at 60 °F.

Fuel Technology

lighter API gravity value is desired as more amount of gas fraction, naphtha and gas oils can be produced from the lighter crude oil than with the heavier crude oil. Therefore, crude oil with high values of API gravity are expensive to procure due to their quality.

Table 2: Classification of crude oils

Crude Category	Gravity
Light crudes	API > 38
Medium crudes	38 > API > 29
Heavy crudes	29 > API > 8.5
Very heavy crudes	API < 8.5

2. Watson characterization factor

The Watson characterization factor is usually expressed as:

$$K = (TB)^{1/3} / \text{specific gravity}$$

Where TB is the average boiling point in degrees R taken from five temperatures corresponding to 10, 30, 50, 70 and 90 volume % vaporized. Typically Watson characterization factor varies between 10.5 and 13 for various crude streams. A highly paraffinic crude typically possesses a K factor of 13. On the other hand, a highly naphthenic crude possesses a K factor of 10.5.

Therefore, Watson characterization factor can be used to judge upon the quality of the crude oil in terms of the dominance of the paraffinic or naphthenic components.

Fuel Technology

3. Sulfur content

sulphur is present in the crude oil. crude oils with high sulphur content are termed as sour crude. On the other hand, crude oils with low sulphur content are termed as sweet crude. Typically, crude oil sulphur content consists of 0.5 – 5 wt % of sulphur. Crudes with sulphur content lower than 0.5 wt % are termed as sweet crudes. It is estimated that about 80 % of world crude oil reserves are sour.

4. Viscosity

Viscosity is a measure of the flow properties of the refinery stream. Typically in the refining industry, viscosity is measured in terms of centistokes (termed as cst) or saybolt seconds or redwood seconds. Viscosity is a very important property for the heavy products obtained from the crude oil. The viscosity acts as an important characterization.

5. Flash and fire point

Flash and fire point are important properties that are relevant to the safety and transmission of refinery products. Flash point is the temperature above which the product flashes forming a mixture capable of inducing ignition with air. Fire point is the temperature well above the flash point where the product could catch fire. These two important properties are always taken care in the day to day operation of a refinery.

Fuel Technology

6. Pour point

When a petroleum product is cooled, first a cloudy appearance of the product occurs at a certain temperature. This temperature is termed as the cloud point. Upon further cooling, the product will cease to flow at a temperature. This temperature is termed as the pour point. Both pour and cloud points are important properties of the product streams as far as heavier products are concerned.

7. TBP/ASTM distillation curves

The most important characterization properties of the crude/intermediate/product streams are the TBP/ASTM distillation curves. Both these distillation curves are measured at 1 atm pressure. In both these cases, the boiling points of various volume fractions are being measured. However, the basic difference between TBP curve and ASTM distillation curve is that while TBP curve is measured using batch distillation apparatus consisting of no less than 100 trays and very high reflux ratio, the ASTM distillation is measured in a single stage apparatus without any reflux. Therefore, the ASTM does not indicate a good separation of various components and indicates the operation of the laboratory setup far away from the equilibrium.

Fuel Technology

Crude Oil-Distillation

The process of distillation is the most common method adopted for separating the constituents of crude oil into compounds or groups of compounds having industrial uses.

Crude oil consists of a complex mixture of hydro-carbons widely differing in boiling points. Distillation is done to separate the crude oil into the basic fractions like motor gasoline kerosene, gas oil and fuel oil. The order in which these components emerge as crude oil is distilled is given in Table.1.

Various Crude Oil Distillation Systems

There are four ways in which the crude oil is distilled *i.e.*

- *Shell still distillation* (Obsolete).
- *Single stage distillation unit* (Atmospheric pressure).
- *Two-stage distillation unit* (Atmospheric and high pressure units).
- *Three-stage distillation unit* (High pressure, atmospheric, pressure and vacuum units).

1. Shell Still Distillation of Crude Oil.

It is the oldest and obsolete method of crude oil in which distillation is accomplished in a battery of shell stills as shown in the Fig..1.

Fuel Technology

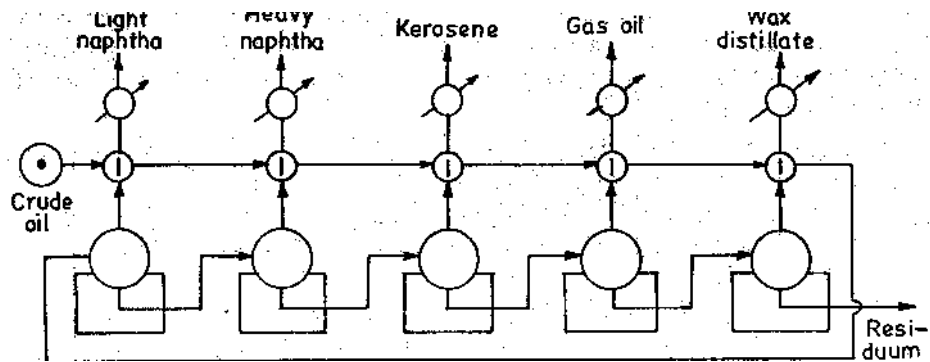

Fig.1:Battery of Shell Still

Preheated crude is charged continuously to horizontal, cylindrical stills which are externally fired. The lightest product (having lowest boiling point and molecular weight) is taken off at the first still (i.e. light naphtha) and the remaining liquid passes on to the following stills where the process is repeated, successively higher boiling point products being obtained in each still which is equipped with bubble cap columns to improve separation of products with overlapping boiling points.

2. Single stage atmospheric distillation unit.

A single-stage crude unit is shown in Fig.3. The crude feed is preheated by the outgoing streams and then enters a direct fired furnace-type heater (pipe still). The materials separate in the distillation column according to their boiling points, the lowest-boiling fraction leaving at the top of the column. Desired products may be withdrawn as side-streams at appropriate points on the column. The side-streams are further fractionated in small columns called strippers. Here, steam is used to free the cut from its more volatile components so that the initial boiling point of the products can be adjusted to its desired value. It is also called straight run distillation of crude oil.

Fuel Technology

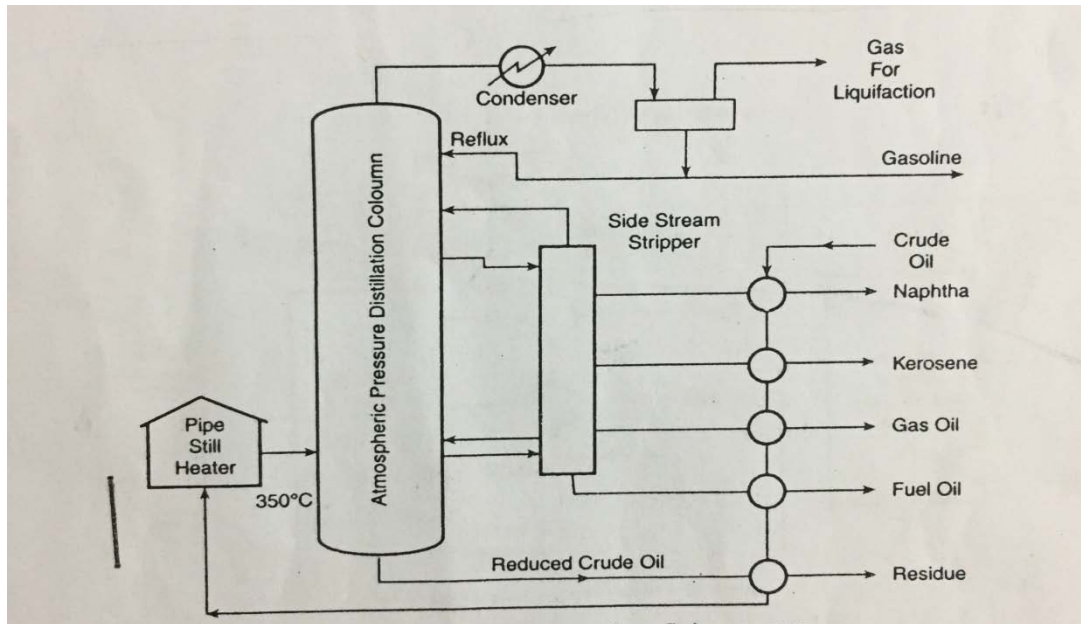

Fig 2: Single Stage Crude Refining Process

3. Two stage distillation unit.

This scheme of distillation includes a *primary tower* which operates at about *3-4 atmospheric pressure* and a *secondary tower* operating at *atmospheric pressure* together with stabiliser. This scheme is used when crude is to be separated into six to ten narrow cuts (*i.e.* products with very close and overlapping boiling points). Two/three sidestreams (*e.g.* gasoline, naphtha) are withdrawn from primary tower while the overhead (gas) product becomes feed to stabiliser. Primary tower bottoms becomes the feed for secondary tower from which side-streams like kerosene, diesel, gas oil etc. are withdrawn at appropriate points after passing through strippers to remove the light components.

Fuel Technology

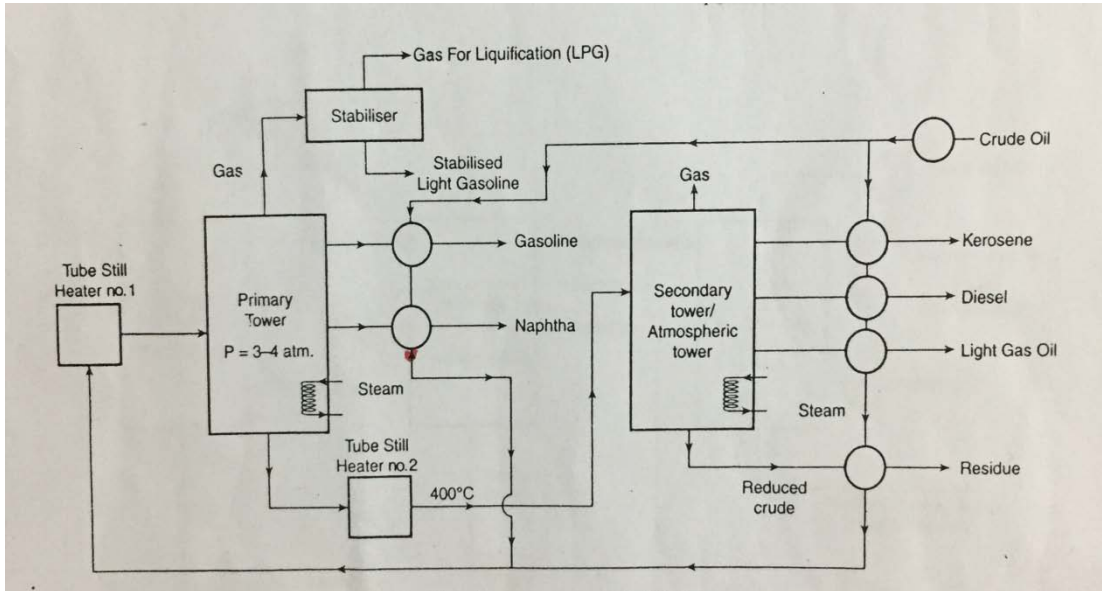

Fig 3: Two Stage Crude Distillation

4. Three stage distillation unit.

This system comprises of all the three *i.e.* pressure, atmosphere and vacuum tower. Because some products of crude are having very high boiling temperature or heat sensitive so that they cannot be distilled at atmospheric pressure. Since boiling point is reduced as the pressure is lowered (*i.e.* vacuum is created), such materials are distilled under vacuum. Vacuum distillation is used for the production of lubricating oils, asphalts and feed to catalytic cracking unit (*i.e.* heavy gas oil).

Fuel Technology

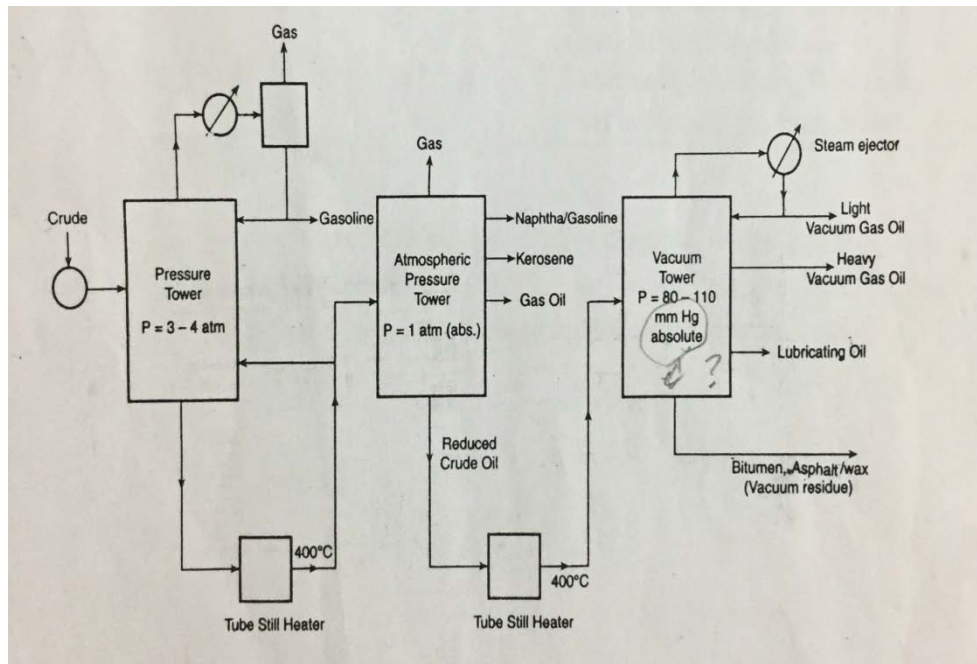

Fig. 4. A flow sheet of Three Stage Crude Distillation

Cracking

Cracking means heating of higher boiling petroleum fractions like heavy fuel oil at high temperature (above decomposition temperature) and pressure to produce lower boiling lighter fractions. It is an endothermic reaction.

The main application of cracking is for production of gasoline from gas oil. It is also done to produce olefins (for petrochemicals production) from gas oil and naphtha, lower viscosity furnace oil (visbreaking) and coke. Important chemical reaction in thermal cracking (non catalytic) which is carried out at comparatively higher pressure (P) (1-7) atm and

Fuel Technology

temperature (450-750) °C by heating the feed are decomposition, isomerisation and polymerization. First, the higher paraffin (n-decane) decomposes to lower paraffin and an olefin.



Types of Cracking:

There are two types of cracking:

1- Thermal cracking

When cracking (breaking larger molecules into smaller ones by heating) is done without any catalyst (which increases the rate of reaction, then it is called (**thermal cracking**)).

There are various thermal cracking processes in which the product yields and characteristics are different some of them:

a- Low temperature and high pressure thermal cracking process:

Feed (residue from atmospheric distillation unit), **Products** (gas, fuel oil and gasoline) T and P 500 °C and 20 atm. This process is also called visbreaking when heavy fuel oil is thermally cracked to reduce its viscosity.

b- High temperature and high pressure process:

Feed (gas oil), **Product** (gas and gasoline), T and P 53 °C and 70 atm.

2-Catalytic Cracking

Cracking in presence of a catalyst is called (**catalytic cracking**). The feed which may be (kerosene, fuel oil, gas oil, lubricating oil), atmospheric or vacuum and cracked residue etc ..is heated in presence of catalyst (like, platinum, nickel, iron silica-alumina etc..) at T (350-650) °C and P (1-15) atm to produce gas, petrol, diesel and residue (coke).

Fuel Technology

Higher temperature gives higher yield of gasoline, where as higher pressure reduce the octane number of gasoline.

Advantages of Catalytic Cracking over Thermal Cracking:

- 1- Pressure and temperature required for catalytic cracking is lower.
- 2- Yield and octane number of petrol production is higher.
- 3- Petrol produced has less quantity of gum and gum forming material.
- 4- Sulphur content of the products is low.

Reforming

Reforming means rearrangement of molecules without much affecting the average molecular weight of feed which is generally naphtha of gasoline boiling rang. Reforming is carried out to produce high quality (octane number) gasoline by heating with or without catalyst the naphtha.

Feed for Reforming:

The feed is generally naphtha produced during straight run distillation of crude oil, catalytic cracking and cooking process. The best result is obtained with naphtha (produced during straight run distillation) having high naphtha content.

Reforming Product:

Besides the main product (reformate) or reformat gasoline, reforming also produces lighter hydrocarbons (gases), hydrogen and traces of very high boiling materials.

Chemical Reaction in Catalytic Reforming:

Octane number increases in the order:

paraffine → olefin → naphthene → iso- paraffin → aromatic

Fuel Technology

The main reaction in the reforming process is dehydrogenation of naphthene to produce aromatics

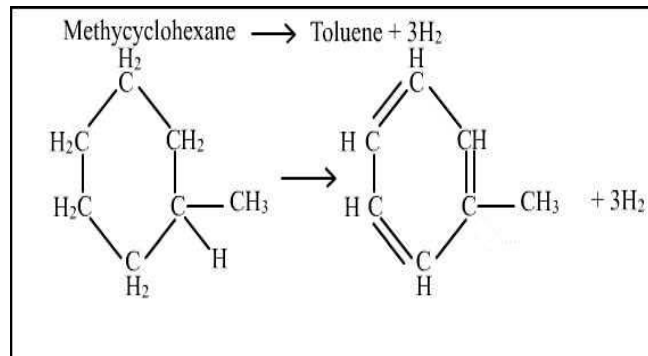

Types of Reforming:

Reforming can be **thermal** or **catalytic** as in the case of cracking. Catalyst apart from accelerating the process also enhances the yield and quality (octane number) of gasoline. The gasoline produced by reforming is called reformed gasoline or reformate. Thermal reforming has been almost completely replaced by catalytic reforming.

- **Thermal Reforming**

This is carried out in absence of catalyst and its similar to high temperature, low pressure thermal cracking. Feed is usually Naphtha and the products are mainly gas (13 -14%) and gasoline (75 -80%) of octane number 81 -86, rest being polymer (unwanted gum) and losses.

Fuel Technology

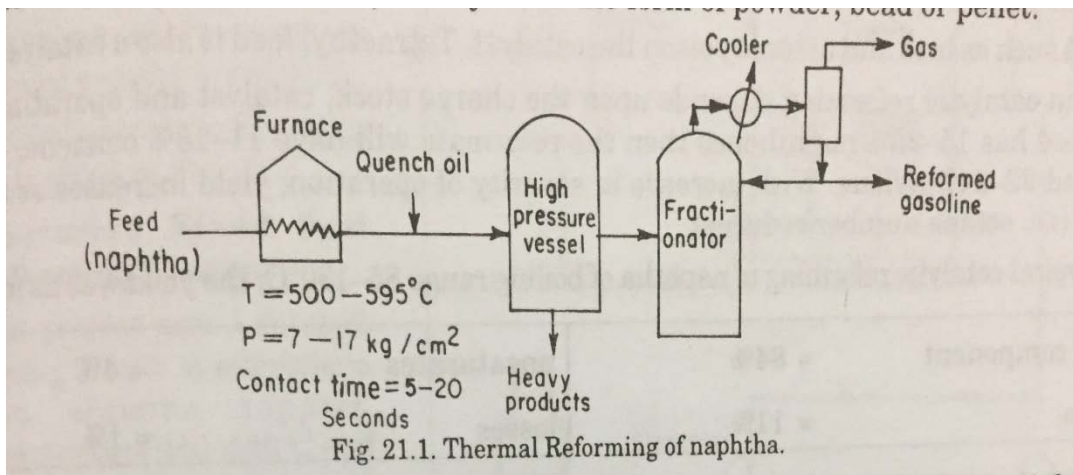

Figure: Thermal Reforming of Naphtha

-Catalytic Reforming

Reforming in the presence of a catalyst is called catalytic reforming.

There are two types of catalyst are used:

- Non- precious metal oxide type (e.g. molybdena or chromia supported on alumina base).
- Precious metal oxide type (e.g. platinum on a silica-alumina or alumina base).

Platinum is more active and selective catalyst.

Dewaxing:

Dewaxing is one of the most important and most difficult processes in lubricating oil manufacturing. There are two types of processes in use today. One uses refrigeration to crystallize the wax and solvent to dilute the oil portion sufficiently to permit rapid filtration to separate the wax from the oil. The other uses a selective hydrocracking process to crack the wax molecules to light hydrocarbons.

Fuel Technology

Solvent Deasphalting

- In this extraction process, which uses propane (or hexane) as a solvent, heavy oil fractions are separated to produce heavy lubricating oil, catalytic cracking feedstock, and asphalt.
- Feedstock and liquid propane are pumped to an extraction tower at precisely controlled mixtures, temperatures (150°-250° F), and pressures of 350-600 psi.
- Separation occurs in a rotating disc contactor, based on differences in solubility.
- The products are then evaporated and steam stripped to recover the propane, which is recycled.
- Deasphalting also removes some sulfur and nitrogen compounds, metals, carbon residues, and paraffins from the feedstock.

Fuel Technology

GASOUS FUEL

Natural Gas, Liquefied Petroleum Gas (LPG)

Natural Gas

It is a mixture of paraffinic hydrocarbons, in which methane is the main constituent. It occurs:

- in the gas field (under the crust of earth) .
- in association with crude petroleum in oil fields.

After delivery from wells, natural gas is processed to remove the solids. It is then treated for recovery of gasoline and liquified natural gas (LNG).

- When natural gas contains very less recoverable condensate ($<15\text{gm}/\text{m}^3$), it is known as ***dry natural gas***.
- while it is termed as **wet natual gas** if recoverable condensate is more ($>50\text{gm}/\text{m}^3$).

This condensate is recovered and is known as(***natural gasoline***)which is used as a blending agent for motor fuel.

The condensate (***natural gasoline***) recovery from gas is done by compressing& cooling or adsorption on a porous solid.

Fuel Technology

Typical composition and properties of natural gas are given in Table.1.

Table (1). Composition and Properties of Natural' Gas

<i>Parameters</i>	<i>Dry and sweet</i>	<i>Wet and sweet gas</i>
<i>Composition (volume%)</i>		
<i>CH₄</i>	<i>96.91</i>	<i>77.22</i>
<i>C₂H₆</i>	<i>1.33</i>	<i>11.18</i>
<i>C₃H₈</i>	<i>0.19</i>	<i>5.83</i>
<i>C₄H₁₀</i>	<i>0.05</i>	<i>2.34</i>
<i>C₅H₁₂</i>	<i>0.02</i>	<i>1.18</i>
<i>CO₂</i>	<i>0.82</i>	<i>0.80</i>
<i>N₂</i>	<i>0.68</i>	<i>1.39</i>
<i>Gross C.V., kcal/Vm³(dry)</i>		<i>11200</i>
<i>Sp. g^ravity (Air = 1)</i>	<i>0.574</i>	<i>0.741</i>

Natural gas of some localities contains large quantity of N₂ and CO plus recoverable amount of helium. Sometimes H₂S are also present in the gas which is recovered as elemental sulphur. H₂S free gas is called a sweet gas.

Natural gas is used as a fuel for:

- cooking, domestic
- industrial heating,
- process furnace and boilers
- fertiliser production
- a source of carbon and hydrogen in chemical industries.

Fuel Technology

Producer Gas

It comprises mainly of CO & N₂ and is produced (in a furnace called 'producer') by blowing air or a mixture of air & steam through hot bed of solid fuels (coal/coke). In the simple gas producer, dry air is blown through a bed of coal/coke of sufficient depth and at a sufficiently high temperature. Gas obtained consists of CO and N₂ in the ratio of (1:2) by volume, with traces of CO₂ and H₂. Above method was modified by addition of steam to the blast to increase the thermalefficiency and moderate the temperature of the fuel bed by generating additional combustible gas by the reaction of steam with carbon, (e.g. $C + H_2O = CO + H_2$)

CO₂ (4 -6), CO (20 -30), H₂ (11 -20), CH₄ (0 -3), N₂ (46 -55)
Calorific value (CV) = 1250-1550 kcal/Nm³
Sp. Gravity (Air = 1) = 0.85-0.90
Combustion Air requirement = 1--1.3 Nm³/Nm³ of producer gas

Producer gas may also contain steam, tarry vapors, Sulphur compound, NH₃ in minor quantity.

Factors Affecting the Composition of Producer Gas

- **Nature of fuel:**

High volatile bituminous coal gives a rich gas, containing small proportion of methane.

- **Operating temperature:**

Low temperature favours high production of CO₂. High temperature favours high production of CO.

Fuel Technology

- **Effect of Steam:**

Water in the coal feed or steam in the air blast increases the proportion of H₂ and CO in the gas, thus raising its calorific value. If excess steam is added, the temperature of gasification is reduced; more CO₂ is formed and the calorific value of the gas is decreased. If steam is not added, there are chances of clinker formation.

Uses of Producer Gas

- Gas for firing in glass melting and open hearth furnaces.
- Producer gas for use in internal combustion engines.
) which takes place with absorption of heat. Producer gas made from either coke or coal, under normal operating condition has a composition (volume %) within the range given below:

Water Gas

It is a medium calorific value gas (about 2800 kcal/Nm³) comprising mainly of CO and H₂. It is prepared by action of superheated steam on a bed of hot coke/coal at about 1000°C as per the reaction.



Since the above reaction is endothermic, the coal cools down after a few minutes and the reaction proceeds in a different way to form carbon dioxide and hydrogen instead of water gas (CO + H₂).

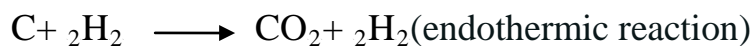

Uses of Water Gas

- It is used as a fuel in furnaces.
- It is also used as a source of hydrogen for ammonia synthesis in fertiliser plant.

Fuel Technology

Liquefied Petroleum Gas (LPG)

It is mainly a mixture of propane and butane used mainly as

- cooking gas in domestic ovens.
- for industrial heating in furnaces (e.g. heating of annealing furnaces).

C_3 (propane etc.) and C_4 (butane etc) hydrocarbons are easily liquified at room temperature with the application of very low pressure. Hence, propane and butane is liquified, stored and transported in light. cylinders. Generally, a mixture of about 80% butane and 20% propane is used for filling in LPG cylinders (also called bottled gas).

- ❖ LPG have high calorific value.
- ❖ LPG is odorless, hence odorants like mercaptans (50 ppm) or sulphides are added to detect its leakage from cylinders by smell, as mercaptans have very pungent smell.
- ❖ The lighter grade LPG commercially available contains 90% propane and 10% butane.

Use of LPG as Engine Fuel:

Use of LPG in a spark ignition engine offers following

Advantages:

- LPG is readily miscible with air.
- it leaves less combustion chamber deposits.
- gives lower emission of pollutants like unburnt hydrocarbons & carbon monoxide.
- Its anti-knocking properties .

Fuel Technology

Disadvantages

- LPG has to be stored & transported in bulky tanks capable of withstanding very high pressure.
- Some of the unsaturated compounds present in LPG have a comparatively poor octane number and are prone to causing high speed knock.

Refinery Gases

Gases obtained during distillation, cracking and other processing of petroleum and its fractions which contain paraffins (e.g. methane, ethane, propane and butane), olefins (e.g. ethylene, propene and butene), hydrogen sulphide and hydrogen are called refinery gases. A possible range of volumetric composition and properties of refinery gases is given in Table 3.

Table (3) Composition and Properties of Refinery Gas

Propane + Propane	40-55%
Butene + Butane	upto30%
Ethylene + Ethane	8-12%
Methane	8-10%
Hydrogen	6-8%
Hydrogen sulphide	6-8%
Calorific value, kcal/Nm ³	20500
Specific gravity (Air = 1)	1.35

Fuel Technology

Table (4) Yield of refinery gases in the form of LPG in various refinery processes

Refinery process	Feedstock	Main products	Yield of LPG (weight% on feed)
Visbreaking/coking	Residuum, heavy gas	Coke	5-10
Catalytic reforming	Light virgin naphtha	Aromatics, gasoline	5-10
Alkylation/Polymerisation	Butane-unsaturated	Gasoline	10-15
Catalytic cracking	Gas oil	Ethylene, propylene petrochemicals)	15-20

BURNERS

Fuel Technology

Principles of Burner Design

How does combustion occur?

The release of potential energy of fuel by combustion with air requires several stages, namely.

- Mixing of air and fuel
- Ignition of the mixture
- Chemical reaction
- Disposal of products of combustion from the reaction site.

So that fresh reactants are available, that each mole of carbon theoretically requires 1 mole of oxygen for complete combustion. But 1 mole of oxygen is obtained from 4.76 moles of air. That means 3.76 moles of nitrogen are present with 1 mole of oxygen. Nitrogen is inert and does not take part in combustion therefore mixing of air + fuel is important.

What is a burner?

A burner is a mechanical device that

Fuel Technology

- supplies required amount of fuel and air
- creates condition for rapid mixing of fuel and air
- produces a flame which transfers thermal energy to furnace.

In oil burners, oil is atomized into a fine spray by a spray nozzle and air is supplied for combustion in the spray chamber. Alternatively oil may be atomized by high speed air to produce a fine dispersion of droplets into air. There are liquid fuel and gaseous fuel burners. In liquid fuel burner, oil is heated and atomised either mechanically or by high speed gaseous jet. In mechanical methods oil is atomised by means of a rotating disc or cup or by swirler as shown in the figure 1a and b.

BURNERS

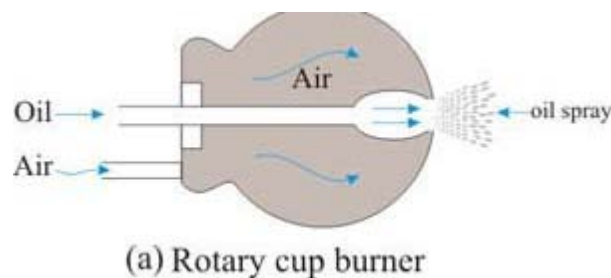

Figure1: Spreading of an axis-symmetric jet in the surrounding

Mechanical atomization produces wider spray of oil and wide flame area with uniform droplet size.

In atomization, compressed air or steam is the atomizing fluid. Air atomization produces higher flame temperature than steam atomization. Steam atomization is preferred for viscous oil.

Fuel Technology

A gaseous fuel burner could either be of premixed type or diffusion type. In a pre-mixed type gas and air are mixed prior to passing through the nozzle. In diffusion type fuel and some amount of air is mixed and the mixture is passed through the burner. Rest air for combustion is supplied in the furnace chamber. Combustion of fuel is controlled by the rate of mixing of air and fuel. In these burners small portion of air is mixed with fuel as primary air and the rest amount, known as secondary air is supplied in the furnace. Industrial burners for gaseous fuel are diffusive type.

Mixing of air and gaseous fuel

In diffusion burner air and gaseous fuel are supplied separately in the furnace. In most combustion systems mass of air is at least 8 to 9 times than fuel. When air and fuel pass through the burner, the momentum flux of air is several times greater than fuel. Some fraction of total air is mixed with the fuel and this air is known as primary air. Rest amount of air, known as secondary air is supplied in the furnace through.

Fuel Technology

FURNASES

ISSUE IN FURNACES DESIGN:

- 1) Source of energy in processing of raw materials is fossil fuel in most cases. Even if electric energy is used, it is also derived from fossil fuels.
- 2) In chemical processing, fluid flow is important. Liquid and gases are flowing at high temperature so erosion and corrosion of the refractory is important. In addition, fluid flow also influences the rates of heat and mass transfer.
- 3) Atmosphere in the furnace is also important to avoid oxidation of the material being heated
- 4) Control of furnace temperature is also an important issue. Overheating and under-heating lead to inefficient utilization of fuel and also overheating or under-heating of material. Furnace should be equipped with temperature measurement and control device.
- 5) Furnaces are both batch and continuous type. In the continuous type for example in heating of ferrous material for hot working, the furnace chamber consists of preheating, heating and soaking zones. The material enters through the preheating zone and exits the soaking zone for rolling.

Fuel Technology

6) In the batch furnaces, the load is heated for the fixed time and then discharged from the furnace. There are different types of batch furnaces like box type, integral quench type, pit type and car bottom type

7) The products of combustion are moving at high speeds in the furnace. The flow of products of combustion is important to obtain rapid heat transfer and minimum thermal gradient.

Fuel Technology

Fuel Technology